

**CITY OF MISSION VIEJO
CALIFORNIA**

**PLANS, SPECIFICATIONS
AND CONTRACT DOCUMENTS**

FOR

**HIGHWAY SAFETY IMPROVEMENT PROGRAM (HSIP)
CITYWIDE AUDIBLE PEDESTRIAN PUSH BUTTON
IMPROVEMENTS
VARIOUS LOCATIONS**

CIP 23255

**PREPARED BY
CITY OF MISSION VIEJO
200 CIVIC CENTER
MISSION VIEJO, CALIFORNIA 92691
(949) 470-3068**

NOVEMBER 2023

STATE PROJECT NO. HSIPL-5451(037)

CITY OF MISSION VIEJO
CALIFORNIA

PLANS, SPECIFICATIONS AND CONTRACT DOCUMENTS

FOR

HIGHWAY SAFETY IMPROVEMENT PROGRAM (HSIP)
CITYWIDE AUDIBLE PEDESTRIAN PUSH BUTTON
IMPROVEMENTS

VARIOUS LOCATIONS

CIP 23255

Prepared By:



Mario Gutierrez, Associate Engineer

10/31/23

Date

Approved By:



Mark Chagnon, Director of Public Works

10/31/23

Date

**CITY OF MISSION VIEJO
TABLE OF CONTENTS**

**HIGHWAY SAFETY IMPROVEMENT PROGRAM (HSIP)
CITYWIDE AUDIBLE PEDESTRIAN PUSH BUTTON IMPROVEMENTS
VARIOUS LOCATIONS
CIP NO. 23255**

NOTICE INVITING SEALED BIDS	NB-1
INSTRUCTIONS TO BIDDERS	IB-1
PROPOSAL DOCUMENTS	
Proposal	P-1
Bidder's Information	P-2
List of Subcontractors	P-3
References	P-4
Designation of Sureties	P-4
Bidder's Statement of Past Contract Disqualifications	P-5
Non-Collusion Affidavit	P-7
Bid Bond	P-9
Proposal Bid Sheet	P-12
CONTRACT DOCUMENTS	
Contract Agreement	CA-1
Faithful Performance Bond	CA-4
Labor and Material Payment Bond	CA-6
Compensation Insurance Certificate	CA-8
GENERAL SPECIFICATIONS	
Scope of Work	GS-1
Location of Work	GS-1
Time of Completion	GS-1
Traffic Requirements	GS-1
Utility Requirements	GS-1
Flow and Acceptance of Water	GS-2
Removal of Water	GS-2
Standard Specifications	GS-3
Wage Rates and Labor Code Requirements	GS-4
Clayton Act and Cartwright Act	GS-4
Substitution of Securities	GS-4
SPECIAL PROVISIONS	
PART I — GENERAL PROVISIONS	SP-1
LOCATION MAP	APPENDIX A
APPLICABLE STANDARD PLANS	APPENDIX B
EXCERPTS FROM CALIFORNIA LABOR CODE	APPENDIX C
CONSTRUCTION PLANS	APPENDIX D
ENCROACHMENT PERMIT APPLICATION	APPENDIX E
VENDOR APPLICATION	APPENDIX F
W9 REQUEST FOR TAXPAYER	APPENDIX G

**CITY OF MISSION VIEJO
NOTICE INVITING SEALED BIDS**

**HIGHWAY SAFETY IMPROVEMENT PROGRAM (HSIP)
CITYWIDE AUDIBLE PEDESTRIAN PUSH BUTTON IMPROVEMENTS
VARIOUS LOCATIONS
CIP 23255**

NOTICE IS HEREBY GIVEN that sealed bids will be received by the **City of Mission Viejo**, as "AGENCY," for furnishing all materials, equipment, tools, labor and incidentals as required for the above-stated project in strict accordance with the specifications and drawings on file at the office of the City Clerk of the **City of Mission Viejo**.

Bids will be received at the office of the City Clerk, 200 Civic Center, **City of Mission Viejo**, until the hour of **10:00 a.m. on Tuesday, December 19, 2023**, at which time and place the bids will be publicly opened and read aloud. Bids shall be submitted in sealed envelopes marked on the outside, "**SEALED BID FOR HIGHWAY SAFETY IMPROVEMENT PROGRAM (HSIP) CITYWIDE AUDIBLE PEDESTRIAN PUSH BUTTON IMPROVEMENTS (CIP 23255)**".

The Work to be constructed under the Contract hereunder is located in the **City of Mission Viejo**. The Work to be performed consists of furnishing all materials, equipment, tools, labor, and incidentals as required by the Plans, Specifications, and Contract Documents for the above-stated Contract. The general items of Work consist of installing audible pedestrian push button devices on existing traffic signal infrastructure including central control units and all appurtenant work.

The Agency reserves the right, after opening bids, to reject any or all bids, or to make award to the lowest responsive and responsible bidder and reject all other bids; to waive any informality in the bidding; and to take all bids under advisement for a period of 45 days. Bids will be compared on the basis of the Engineer's estimate of the quantities of the several items of work as shown on the Bid Sheets. Only such plans, specifications, and items of work as are appropriate shall apply to the work as bid.

At the time of Contract award to a bidder, the bidder shall possess a Class A Contractor's License or a Class C-10 Electrical Contractor's License issued by the State of California.

Each bid must be accompanied by all required pages of the Proposal (see Instructions to Bidders), including a certified or cashier's check, or a corporate surety bond on the form furnished by the AGENCY, as a guarantee that the bidder will, if an award is made to it in accordance with the terms of its bid, promptly secure workmen's compensation insurance and liability insurance, execute a contract in the required form, and furnish satisfactory bonds for the faithful performance of the Contract and for the payment of claims of material and laborers thereunder. Said check or bidder's bond shall be in an amount not less than 10% of the amount of the bid.

The successful bidder will be allowed to substitute securities or establish an escrow in lieu of retainage, pursuant to Public Contract Code Section 22300, and as described in the Agreement between Agency and Contractor and General Conditions.

The Performance and Payment Bonds shall be submitted before execution of the Contract. The Performance Bond shall be not less than 100% of the total amount of the bid price named in the Contract. The Payment Bond shall be not less than 100% of the total amount of the bid price named in the Contract. The AGENCY reserves the right to reject any bond if, in the opinion of the AGENCY Attorney, the Surety's acknowledgment is not in the form included in the Contract Documents or in another form substantially as prescribed by law.

In accordance with provisions of Section 1773.2 (amended 1977) of the California Labor Code copies of the prevailing rate of per diem wages as determined by the State Director of Industrial Relations are on file in the office of the City Clerk of the **City of Mission Viejo**. It shall be mandatory upon the Contractor to whom the Contract is awarded and upon any subcontractor under him to pay not less than said specified rates to all workmen employed by them in the execution of the Contract.

The Contractor and all Subcontractors, of any tier, must comply with the requirements of the California Labor Code including but not limited to Sections §§1715.5, 1725.5, 1771.1, 1771.1a, 1771.4(a)(1), 1774, 1775, 1776, 1777.5, 1813 and 1815. A contractor or subcontractor shall not be qualified to submit a bid or to be listed in a bid proposal subject to requirements of Public Contract Code Section 4104, nor shall it be qualified to enter into, or engage in the performance of, any contract of public work, unless it is currently registered and qualified under Labor Code Section

1725.5 to perform public work (as "public work" is defined by Division 2, Part 7, Chapter 1 (§§1720 et seq.) of the Labor Code). [Note: Required in the Notice by Labor Code §1771.1(b).]

Contractors are required to register with the Department of Industrial Relations (DIR). Notwithstanding any other requirements (*including federal labor requirements*), this contract is subject to compliance monitoring and enforcement by the Department of Industrial relations (DIR).

The City of Mission Viejo hereby notifies all bidders that it will affirmatively ensure that in any Contract entered into pursuant to this advertisement, Disadvantaged Business and Underutilized Disadvantaged Business Enterprises will be afforded full opportunity to submit bids in response to this invitation and will not be discriminated against on the grounds of race, creed, color, or national origin in consideration for an award.

A full set of drawings and specifications is available for inspection without charge at the Engineering Counter of the City Hall of the **City of Mission Viejo**.

Complete sets of said Contract Documents may be purchased at a cost of **\$50.00 (Fifty Dollars)** per set and are obtainable from the **City of Mission Viejo**, 200 Civic Center, Engineering Counter, Mission Viejo, California 92691, 949-470-3040. No refund will be made of any charges for sets of contract documents. Plans and specifications can be mailed for an **additional \$20.00 (Twenty Dollars)** per set. For additional information, contact the Project Manager **Mario Gutierrez** at **949-470-3068** or **MGutierrez@cityofmissionviejo.org**.

Dated this 15th day of November, 2023.



Kimberly Schmitt
City Clerk

City of Mission Viejo
200 Civic Center
Mission Viejo, California 92691

**CITY OF MISSION VIEJO
INSTRUCTIONS TO BIDDERS**

**HIGHWAY SAFETY IMPROVEMENT PROGRAM (HSIP)
CITYWIDE AUDIBLE PEDESTRIAN PUSH BUTTON IMPROVEMENTS
VARIOUS LOCATIONS
CIP 23255**

1. PROPOSAL FORMS AND REVIEW OF PLANS AND SPECIFICATIONS

Bids shall be submitted in writing on the Proposal forms provided by the AGENCY. All information requested therein must be clearly and legibly set forth in the manner and form indicated. The Proposal must include all pages of the Proposal form with all of the required information, including but not limited to the Bidder's Information, Proposal Bid Sheet, List of Subcontractors, Bidder's Statement of Past Contract Disqualifications, Non-Collusion Affidavit, Bid Bond, Iran Contracting Act Certification (if required), and Sufficient Funds Declaration. The AGENCY will not consider any proposal not meeting these requirements.

In addition, the AGENCY shall not accept any bid or enter into any contract without proof of the Bidder's current registration to perform public work under Labor Code Section 1725.5; and the Bidder shall not accept any sub-bid or enter into any subcontract without proof of the subcontractor's current registration to perform public work under Labor Code Section 1725.5.

Each bidder must review the plans and specifications in its capacity as a contractor prior to submitting its bid, and any errors must be reported to the AGENCY.

2. PROPOSAL GUARANTEE (BID BOND)

Proposals must be accompanied by a proposal guarantee consisting of a certified check or bid bond payable to the AGENCY in the minimum amount of ten percent (10%) of the total amount bid. Any proposal not accompanied by such a guarantee will not be considered. If a bidder to whom a Contract is awarded fails or refuses to execute the Contract Documents or furnish the required insurance policies and bonds as set forth in those documents, the proposal guarantee shall be forfeited to the AGENCY. The proposal guarantees of all bidders will be held until the successful bidder has properly executed all Contract Documents.

3. PROPOSED SCHEDULE

The Contractor shall have Fifty (50) Working Days to Complete the Work.

November 14, 2023	Permission to go to bid
November 17, 2023	Advertise in trade journals and on the Internet
December 8, 2023	Submit Questions No Later than December 5, 2023 at 5:00 p.m.
December 19, 2023	Bid opening at 10:00 a.m., City Clerk's counter, City Hall 2 nd Floor
January 9, 2024	Award of contract consideration
January 15, 2024	Notice to Proceed with Construction

This schedule is proposed. Should the "Construction begins" date slip, the contract days take precedence.

4. NON-COLLUSION AFFIDAVIT

Bidder shall declare that the only persons or parties interested in the Proposal as principals are those named therein; that no officer, agent, or employee of the AGENCY is personally interested, directly or indirectly, in the Proposal; that the Proposal is made without connection to any other individual, firm, or corporation making a bid for the same Work; and that the Proposal is in all respects fair and without collusion or fraud. The Non-Collusion Affidavit shall be executed and submitted with the Proposal.

5. PROPOSAL BID SHEET

Bidders shall give unit prices for each and all of the items set forth. No aggregate bids will be considered. The bidder shall set forth for each item of work, in clearly legible figures, a unit item price and a total for the item in the respective spaces provided for this purpose. The quantities listed in the bid sheets are supplied to give an indication of the general scope of Work, but the accuracy of figures is not guaranteed and the bidder shall make its estimates from the drawings. In case of a variation between the unit price and the totals shown by the bidder, the unit price will be considered to be the bid.

6. DELIVERY OF PROPOSAL

Proposals may be mailed or delivered by messenger. However, it is the bidder's responsibility alone to ensure delivery of the Proposal to the hands of the AGENCY's designated official prior to the bid opening hour stipulated in the "Notice Inviting Informal Bids." Late proposals will not be considered. Proposals shall be enclosed in a sealed envelope plainly marked on the outside, "**SEALED BID FOR HIGHWAY SAFETY IMPROVEMENT PROGRAM (HSIP) CITY WIDE AUDIBLE PEDESTRIAN PUSH BUTTON IMPROVEMENTS (CIP 23255)**".

7. WITHDRAWAL OF PROPOSALS

A proposal may be withdrawn by a written request signed by the bidder. Such requests must be delivered to the AGENCY's designated official prior to the bid-opening hour stipulated in the "Notice Inviting Sealed Bids." The withdrawal of a Proposal will not prejudice the right of the bidder to submit a new Proposal, providing there is time to do so. Proposals may not be withdrawn after said hour without forfeiture of the proposal guarantee, unless withdrawal is allowed under law.

8. IRREGULAR PROPOSALS

Unauthorized conditions, limitations, or provisions attached to a Proposal will render it irregular and may cause its rejection. The completed Proposal forms shall be without interlineations, alterations or erasures. Notwithstanding the foregoing, the City may waive such if allowed by law, and if, in the City's discretion, it deems that waiver is in the City's best interest and that such interlineations, alterations or erasures do not substantially alter the written response or create an unfair advantage to such bidders. Alternative Proposals will not be considered unless specifically requested. No oral, telegraphic or telephonic Proposal, modification or withdrawal will be considered.

9. TAXES

No mention shall be made in the Proposal of Sales Tax, Use Tax, or any other tax, as all amounts bid will be deemed and held to include any such taxes, which may be applicable.

10. DISQUALIFICATION OF BIDDERS

In the event that any bidder on the Contract submits a proposal on another contract on the same work of improvement, all such proposals will be rejected and the bidder will be disqualified. This restriction does not apply to subcontractors or suppliers who may submit quotations to more than one bidder.

The Contract will not be awarded or executed unless the Bidder is licensed in accordance with the provisions of the State Business and Professions Code.

11. INTERPRETATION OF PLANS AND DOCUMENTS

If any person contemplates submission of a bid for the proposed Contract and is in doubt as to the true meaning of any part of the plans, specifications or other proposed Contract Documents, or finds discrepancies in, or omissions from, the drawings or specifications, he may submit to the Engineer of said AGENCY a written request for an interpretation or correction thereof. The person submitting the request will be responsible for its prompt delivery. Any interpretation or correction of the proposed documents shall be made only by addendum duly issued and copy of such addendum will be mailed or delivered to each person receiving a set of such documents. The Engineer will not be responsible for any other explanation or interpretations of the proposed documents.

12. ADDENDA OR BULLETINS

The effect of all addenda to the Contract Documents shall be considered in the bid, and said addenda shall be made a part of the Contract Documents and shall be returned with them. Before submitting its bid, each bidder shall inform

himself as to whether or not any addenda have been issued, and failure to cover in this bid any such addenda issued, may render his bid irregular and may result in its rejection by the AGENCY.

13. LEGAL RESPONSIBILITIES

All Proposals must be submitted, filed, made, and executed in accordance with State and Federal laws relating to bids for contracts of this nature whether the same are expressly referred to herein or not.

Any bidder submitting a Proposal shall by such action thereby agree to each and all of the terms, conditions, provisions, and requirements set forth, contemplated, and referred to in the Plans, Specifications, and Contract Documents, and to full compliance therewith.

14. AWARD OF CONTRACT

The award of contract, if made, will be to the most responsible Bidder as determined solely by the City, pursuant to the City's Plans, Specifications and Contract Documents and in the best interests of the City pursuant to law. At the time of contract award, the successful bidder shall hold the contractor's license(s) required in Notice Inviting Bids. Additionally, the AGENCY reserves the right to reject any or all Proposals, to accept any bid, to waive any irregularity if allowed by law, and to take the bids under advisement for the period of time stated in the "Notice Inviting Bids," all as may be required to provide for the best interests of the AGENCY. In no event will an award be made until all necessary investigations are made as to the responsibility and qualifications of the bidder to whom the award is contemplated.

No bidder may withdraw its proposal for a period of forty-five (45) days after the time set for opening thereof, unless permitted by law. However, the AGENCY will return all proposal guarantees within ten (10) days after the award of the Contract or rejection of the bids, as the case may be, to the respective bidders whose Proposals they accompany.

15. LABOR CODE

Pursuant to the provisions of Section 1773 of the Labor Code of the State of California, the AGENCY has obtained the general provisions rate of per diem wages and the general prevailing rate for holiday and overtime work in this locality for each craft, classification, or type of workman needed to execute the Contract from the State Director of the Department of Industrial Relations (DIR). It shall be the responsibility of the prime Contractor to comply with all applicable sections of the Labor Code.

Travel and subsistence payments to each workman needed to execute the Work shall be made as such travel and subsistence payments are defined in the applicable collective bargaining agreements filed in accordance with Section 1773.8 of the Labor Code.

The Contractor shall comply with the provisions of Section 1774 of the Labor Code. Failure to comply with the subject section will subject the Contractor to penalty and forfeiture provisions of Section 1775 of the Labor Code.

Pursuant to the provisions of Section 1770 of the Labor Code, the general prevailing rate of wages has been ascertained (which rate includes employer payments for health and welfare, vacation, pension and similar purposes) applicable to the work to be done, for straight time, overtime, Saturday, Sunday, and holiday work. The holiday wage rate listed shall be applicable to all holidays recognized in the collective bargaining agreement of the particular craft, classification, or type of workmen concerned.

This project is subject to compliance registration, monitoring, and enforcement by the DIR. (See, among others, Labor Code Sections 1715.5, 1725.5, 1771.1 and 1771.4.)

The AGENCY will not recognize any claim for additional compensation because of the payment by the Contractor of any wage rate in excess of the prevailing wage rate or the Federal Minimum Wage Rate (whichever is greater) as set forth in the Contract. The possibility of wage increases is one of the elements to be considered by the Contractor in determining its bid, and will not under any circumstances be considered as the basis of a claim against the AGENCY on the Contract.

The Contractor and subcontractors shall comply with Section 1777.6 which stipulates that it shall be unlawful to refuse to accept otherwise qualified employees as registered apprentices solely on the grounds of race, religious creed, color, national origin, ancestry, sex, or age, except as provided in Section 3077, of such employee.

16. WORKER'S COMPENSATION CERTIFICATE

Section 3700 of the State Labor Code requires that every employer shall secure the payment compensation by either being insured against liability to pay compensation with one or more insurers or by securing a certificate of consent to self-insure from the State Director of Industrial Relations. In accordance with this section and with Section 1861 of the State Labor Code, the contractor shall sign a Compensation Insurance Certificate, which is included with the Contract Agreement, and submit same to City along with the other required Contract Documents prior to performing any Work. Reimbursement for this requirement shall be considered as included in the various items of Work.

17. CLAYTON ACT AND CARTWRIGHT ACT

In accordance with Section 7103 of the Public Contract Code, in entering the Contract to supply goods, services, or materials, the Contractor and its subcontractors offer and agree to assign to the AGENCY all rights and interest in and all causes of action it may have under Section 4 of the Clayton Act (15 U.S.C. Sec. 15) or under the Cartwright Act (Chapter 2 [commencing with Section 16700] of Part 2 of Division 7 of the Business and Professions Code), arising from purchases of goods, services, or materials pursuant to the Contract or the subcontracts. This assignment shall be made and become effective at the time the AGENCY tenders final payment to the Contractor, without further acknowledgment by the parties.

18. SUBLETTING AND SUBCONTRACTING

Pursuant to the Subletting and Subcontracting Fair Practices Act (commencing with Section 4100 of the Public Contract Code), bidders are required to list in their Proposal the name, location of place of business, license number, and the portion of the Work of each subcontractor who will perform Work or labor or render services in or about the construction of the Work or improvement, and each subcontractor who specially fabricates and installs a portion of the Work or improvement according to detailed drawings contained in the Plans and Specifications, but only if (a) for a Contract for construction of streets or highways, including bridges, the dollar amount of the subcontractor's work is in excess of \$10,000 or ½ of 1% of the total bid in the Proposal, whichever is greater; or (b) for all other Contracts, the dollar amount of the subcontractor's work is in excess of ½ of 1% of the total bid in the Proposal. Failure to list a subcontractor for a portion of the work means that the prime Contractor will do that portion of the Work. It is the AGENCY's intent for the Subletting and Subcontracting Fair Practices Act to apply to all phases of the Work.

Attention is directed to the provisions in Sections 10262 and 10262.5 of the Public Contract Code and Section 7108.5 of the Business and Professions Code concerning prompt payment to subcontractors. The Contractor shall return all moneys withheld in retention from the subcontractor within 30 days after receiving payment for Work satisfactorily Completed, even if the other Contract Work is not Completed and has not been accepted by the Agency. This requirement shall not be construed to limit or impair any contractual, administrative, or judicial remedies otherwise available to the Contractor or subcontractor in the event of a dispute involving late payment or nonpayment by the Contractor or deficient subcontract performance or noncompliance by a subcontractor.

19. INSURANCE

Prior to commencement of Work, Contractor shall obtain, provide, and maintain at its own expense policies of insurance of the type and amounts described below and in a form satisfactory to City of Mission Viejo ("City"). If Contractor uses existing coverage to comply with these requirements and that coverage does not meet the requirements set forth herein, Contractor agrees to amend, supplement, or endorse the existing coverage to do so.

General Liability Insurance. Contractor shall maintain a policy of general liability insurance against any and all claims arising out of or in connection with the work performed for this Project with coverage at least as broad as ISO form CG 00 01. Contractor shall provide coverage in an amount not less than two million dollars (**\$2,000,000.00**) per occurrence, four million dollars (**\$4,000,000.00**) general aggregate, for bodily injury, personal injury, and property damage, and a four million dollar (**\$4,000,000.00**) completed operations aggregate. The policy shall be endorsed to reflect that the per occurrence and aggregate coverage shall apply on a per PROJECT basis, coverage available shall not be eroded by other claims on other projects. The policy must include contractual liability that has not been amended. Any endorsement restricting standard ISO "insured contract" language will not be accepted. The policy shall name City of Mission Viejo, its officers, officials, employees, agents, and volunteers as additional insureds, covering both ongoing and completed operations, using ISO additional insured endorsement forms CG 20 10 and CG 20 37, or equivalent form(s). Coverage provided by Contractor shall be primary, and any insurance or self-insurance procured or maintained by City shall not be required to contribute with it. Coverage shall not be limited to the vicarious liability or supervisory role of any additional insured.

Automobile Liability Insurance. Contractor shall maintain automobile insurance at least as broad as Insurance Services Office form CA 00 01 covering bodily injury and property damage for all activities of the Contractor arising out of or in connection with Work to be performed for this Project, including coverage for any owned, hired, non-owned, or rented vehicles, in an amount not less than one million dollars (\$1,000,000.00) combined single limit for each accident.

Workers' Compensation/Employers' Liability. Contractor acknowledges awareness of Section 3700 *et seq.* of the *California Labor Code*, which requires every employer to be insured against liability for workers' compensation. Contractor covenants that it shall comply with such provisions prior to commencement of work performed for this Project. Contractor shall obtain and furnish to City workers' compensation insurance with statutory limits and employer's liability insurance in an amount not less than one million dollars (**\$1,000,000.00**) per accident for bodily injury or disease. Contractor shall require all subcontractors to provide such workers' compensation and employer's liability insurance for all of subcontractors' employees. Contractor shall submit to City, along with the certificate of insurance, a waiver of subrogation endorsement in favor of City, its officers, agents, employees, and volunteers. Contractor shall similarly require all subcontractors to waive subrogation.

Umbrella or Excess Liability Insurance. (If required to meet higher limits). Contractor shall obtain and maintain an umbrella liability insurance policy with limits that will provide bodily injury, personal injury, and property damage liability coverage, including commercial general liability, automobile liability, and employer's liability. Such policy or policies shall include the following terms and conditions:

- A. A drop-down feature requiring the policy to respond if any primary insurance that would otherwise have applied proves to be uncollectible in whole or in part for any reason, other than bankruptcy or insolvency of said primary insurer;
- B. "Pay on behalf of" wording as opposed to "reimbursement";
- C. Concurrency of effective dates with primary policies.

Should Contractor obtain and maintain an excess liability policy, such policy shall be excess over commercial general liability, automobile liability, and employer's liability policies. Such policy or policies shall include wording that the excess liability policy follows the terms and conditions of the underlying policies.

Cyber technology errors and omissions. Contractor shall procure and maintain cyber technology errors and omissions insurance with limits of **\$1,000,000** per occurrence/loss, **\$2,000,000** general aggregate, which shall include the following coverage:

- a. Liability arising from the unauthorized release of information for which an entity has the legal obligation to keep private, such as personally identifiable information (PII) and protected health information (PHI).
- b. Network security liability arising from the unauthorized use of, access to, or tampering with computer systems, including hacker or denial of service attacks.
- c. Liability arising from the failure of technology products (software and hardware) required under the contract for Contractor to properly perform the intended services.
- d. Claims alleging the failure of computer security that result in the transmission of malicious code, deletion, destruction or alteration of data, or the denial of service.
- e. Electronic Media Liability arising from personal injury, plagiarism or misappropriation of ideas, domain name infringement or improper deep-linking or framing, and infringement or violation of intellectual property rights.
- f. Liability arising from the rendering, or failure to render, professional services.
- g. Defense costs in regulatory proceedings (state and federal) involving a violation of privacy laws or intellectual property rights.
- h. Crisis management and other expert services.

If coverage is maintained on a claims-made basis, the Contractor shall maintain such coverage for an additional three (3) years following termination of the contract.

Self-Insured Retentions

Any self-insured retentions must be declared to and approved by City. City reserves the right to require that self-insured retentions be eliminated, lowered, or replaced by a deductible, or require proof of ability to pay losses and related investigations, claim administration, and defense expenses within the retention through confirmation from the underwriter.

Other Insurance Provisions

Proof of Insurance. Contractor shall provide certificates of insurance and required endorsements to City as evidence of the insurance coverage required herein. Insurance certificates and endorsements must be approved by City's Risk Management prior to commencement of Work. Current certification of insurance shall be kept on file with City for the contract period and any additional length of time required thereafter. City reserves the right to require complete, certified copies of all required insurance policies, at any time.

Requirements not Limiting. Requirements of specific coverage features or limits contained herein are not intended as a limitation on coverage, limits on other requirements, or a waiver of any coverage normally provided by any insurance. Specific reference to a given coverage feature is for purposes of clarification only as it pertains to a given issue and is not intended by any party or insured to be all inclusive, or to the exclusion of other coverage, or a waiver or limitation of any type. If the Contractor maintains higher limits than the minimums shown above, the City requires and shall be entitled to coverage for the higher limits maintained by the Contractor. Any available insurance proceeds in excess of the specified minimum limits of insurance and coverage shall be available to the City.

Duration of coverage. Contractor shall procure and maintain for the contract period, and any additional length of time required thereafter, insurance against claims for injuries to persons or damages to property, or financial loss which may arise from or in connection with the performance of the Work for this project by Contractor, their agents, representatives, employees, or subcontractors/subconsultants. Contractor must maintain general liability and umbrella or excess liability insurance for as long as there is a statutory exposure to completed operations claims. City and its officers, officials, employees, agents and volunteers shall continue as additional insureds under such policies.

Primary/noncontributing. Coverage provided by Contractor shall be primary and any insurance or self-insurance procured or maintained by City shall not be required to contribute with it. The limits of insurance required herein may be satisfied by a combination of primary and umbrella or excess insurance. Any umbrella or excess insurance shall contain or be endorsed to contain a provision that such coverage shall also apply on a primary and non-contributory basis for the benefit of City before City's own insurance or self-insurance shall be called upon to protect it as a named insured. For any claims related to this project, the Contractor's insurance coverage shall be primary insurance as respects to the City, its officers, officials, employees, agents, or volunteers. Any insurance or self-insurance maintained by the City, its officers, officials, employees, agents, or volunteers shall be in excess of the Contractor's insurance and shall not contribute with it.

Products/completed operations coverage. Products/completed operations coverage shall extend a minimum of three (3) years after project completion. Coverage shall be included on behalf of the insured for covered claims arising out of the actions of independent contractors. If the insured is using subcontractors, the Policy must include work performed "by or on behalf" of the insured. Policy shall contain no language that would invalidate or remove the insurer's duty to defend or indemnify for claims or suits expressly excluded from coverage. Policy shall specifically provide for a duty to defend on the part of the insurer. The City, its officers, officials, agents, and employees, shall be included as additional insureds under the Products and Completed Operations coverage.

Waiver of Subrogation. All insurance coverage maintained or procured pursuant to these specifications/for this Project shall be endorsed to waive subrogation against City, its elected or appointed officers, agents, officials, employees, and volunteers or shall specifically allow Contractor or others providing insurance evidence in compliance with these specifications to waive their right of recovery prior to a loss. Contractor hereby waives its own right of recovery against City and shall require similar written express waivers and insurance clauses from each of its subcontractors/subconsultants.

Additional Insured Status. The general liability, automobile liability, cyber liability, and umbrella/excess liability policies shall provide, or be endorsed to provide that the City, its officers, officials, employees, agents, and volunteers are to be covered as additional insureds as respects: liability arising out of activities performed by or on behalf of the Contractor, products and Completed operations of the Contractor; premises owned, occupied or used by the Contractor; or automobiles owned, leased, hired, or borrowed by the Contractor. The coverage shall contain no special limitations on the scope of protection afforded to the City, its officers, officials, employees, agents, or volunteers.

Separation of Insureds. A severability of interests provision must apply for all additional insureds ensuring that Contractor's insurance shall apply separately to each insured against whom claim is made or suit is brought, except with respect to the insurer's limits of liability. The policy(ies) shall not contain any cross-liability exclusions.

Notice of Cancellation. Each insurance policy required by this clause shall be endorsed to state that coverage shall not be suspended, voided, canceled by either party, reduced in coverage or in limits except after thirty (30) days' prior

written notice by certified mail, return receipt required, has been given to the City. Contractor agrees to oblige its insurance agent or broker and insurers to provide the City with a thirty (30) day notice of cancellation (except for nonpayment for which a ten (10) day notice is required) or nonrenewal of coverage for each required coverage. If any of the Contractor's insurers are unwilling to provide such notice, then Contractor shall have the responsibility of notifying City immediately in the event of Contractor's failure to renew any of the required insurance coverages, or insurer's cancellation or non-renewal.

Timely notice of claims. Contractor shall give City prompt and timely notice of claims made or suits instituted that arise out of or result from Contractor's performance for this Project, and that involve or may involve coverage under any of the required liability policies.

Any failure to comply with reporting or other provisions of the policies including breaches of warranties shall not affect coverage provided to the City, its officers, officials, employees, agents, or volunteers.

City's rights of enforcement. In the event any policy of insurance required for this Project does not comply with these requirements or is canceled and not replaced, City has the right but not the duty to obtain the insurance it deems necessary, and any premium paid by City will be promptly reimbursed by Contractor or City will withhold amounts sufficient to pay premium from Contractor payments. In the alternative, City may cancel the Agreement.

Prohibition of undisclosed coverage limitations. None of the coverages required herein will be in compliance with these requirements if they include any limiting endorsement of any kind that has not been first submitted to City and approved of in writing.

Additional insurance. Contractor shall also procure and maintain, at its own cost and expense, any additional kinds of insurance, which in its own judgment may be necessary for its proper protection and prosecution of the Work.

Acceptability of Insurers

Insurance is to be placed with insurers with a current A.M. Best's rating of no less than A:VII.

Verification of Coverage

Contractor shall furnish the City with original endorsements effecting coverage required herein. The endorsements are to be signed by a person authorized by that insurer to bind coverage on its behalf. All certificates and endorsements are to be received and approved by the City before Work commences. Contractor's insurer shall provide complete, certified copies of all required insurance policies, including endorsements effecting the coverage required by these specifications.

Contractor acknowledges and agrees that any actual or alleged failure on the part of the City to obtain proof of insurance required for this Project or to inform Contractor of non-compliance with any requirement imposes no additional obligations on the City nor does it waive any rights hereunder.

Subcontractors

Contractor agrees to ensure that its subconsultants, subcontractors, and any other party who is brought onto or involved in the project/service by Contractor (hereinafter collectively "subcontractor"), provide the same minimum insurance coverage and endorsements required of Contractor. Contractor agrees to monitor and review all such coverage and assumes all responsibility for ensuring that such coverage is provided in conformity with the requirements of this section. However, in the event Contractor's subcontractor cannot comply with this requirement, which proof must be submitted to the City, Contractor shall be required to ensure that its subcontractor provide and maintain insurance coverage and endorsements sufficient to the specific risk of exposure involved with subcontractor's scope of work and services, with limits less than required of the Contractor, but in all other terms consistent with the Contractor's requirements under this agreement. This provision does not relieve the Contractor of its contractual obligations under the agreement and/or limit its liability to the amount of insurance coverage provided by its subcontractors. This provision is intended solely to provide Contractor with the ability to utilize a subcontractor who may be otherwise qualified to perform the work or services but may not carry the same insurance limits as required of the Contractor under this agreement given the limited scope of work or services provided by the subcontractor. Contractor agrees that upon request, all agreements with subcontractors, and others engaged in the project, will be submitted to City for review.

20. ARBITRATION

Optional Arbitration: Applicable Law

In lieu of litigation of a dispute, the Contractor and City may agree to submit the dispute to binding arbitration so long as agreed by the parties in writing and approved in writing by the Board as an amendment to the Contract Documents. Except as provided below or as may be agreed upon by the parties in writing, (a) any such arbitration shall be governed by Code of Civil Procedure Sections 1280 et seq., and (b) the arbitration award must be supported by law and substantial evidence, and that the award may be vacated if not so supported, per Code of Civil Procedure Section 1296. Should any provision in this "Arbitration" section be found to be unenforceable, then such provision shall be severed and the parties agree that the remaining provisions shall be binding and enforceable as if adopted absent the unenforceable provision. Should the parties wish to modify any provision in this "Arbitration" section, the parties may do so.

Selection of Arbitrator

If the parties agree to binding arbitration, upon notification of a party's election to proceed with arbitration under this section, the parties shall have thirty (30) days to jointly select an arbitrator. In the event that the parties are unable to reach an agreement as to the selection of an arbitrator, an arbitrator will be selected from the American Arbitration Association's panel of construction arbitrators. There shall be no limit on the number of arbitrators that a party can disqualify with respect to the American Arbitration Association's list of arbitrators.

Amount in Controversy/Discovery

If the parties agree to arbitration, the following would apply:

1. If the amount in controversy is less than \$50,000, then, notwithstanding any other provision of law, the only discovery permitted will be (1) the noticing and taking of one deposition (in accordance with Code of Civil Procedure Section 2025) by each party to the dispute and (2) inspection demands pursuant to Code of Civil Procedure Section 2031.
2. If the amount in controversy is equal to or greater than \$50,000 but less than \$150,000, then, notwithstanding any other provision of law, the only discovery permitted will be (1) the noticing and taking of no more than three depositions (in accordance with Code of Civil Procedure Section 2025) by each party to the dispute and (2) inspection demands pursuant to Code of Civil Procedure Section 2031.
3. If the amount in controversy is equal to or greater than \$150,000, then all discovery rules contained in the California Civil Discovery Act, Code of Civil Procedure Section 2016, et seq., shall apply to the arbitration, except each party will only be allowed to propound no more than fifty (50) special interrogatories, and no requests for admissions shall be permitted.

The above deposition limits shall not be applicable to expert depositions. Experts shall be designated and deposed in accordance with Code of Civil Procedure Section 2034.

Procedure/Evidence

If the parties agree to arbitration, the following would apply:

1. General and specific rules of trial procedure and evidence as set forth in the California Code of Civil Procedure and the California Evidence Code, respectfully, shall apply except that the arbitrator may admit any relevant evidence which he believes should be afforded consideration.
2. Motions for summary judgment and/or summary adjudication of issues shall be permitted only if the amount in controversy is equal to or greater than \$50,000. Motions for summary judgment and/or summary adjudication of issues shall be heard in accordance with the Federal Rules of Civil Procedure, Rule 56. The arbitrator shall also have the authority to decide specific legal and/or factual issues by way of a motion for summary judgment and/or summary adjudication of issues regardless of whether or not such resolve a cause of action.
3. Demurrers and motions for judgment on the pleadings shall not be allowed. The arbitrator shall review the pleadings and, in the arbitrator's sole, discretion a dismissal and/or amendment of a pleading can be ordered.
4. The arbitrator shall conduct a pre-arbitration conference for purposes of coordinating the arbitration. At the pre-arbitration conference, all of the following issues shall be addressed: procedural matters, exchange of exhibits, witness lists, motions in limine, arbitration briefs, and the potential for narrowing issues and/or factual

disputes by stipulation or by bifurcating the arbitration. The arbitrator can bifurcate specific factual and/or legal issues in addition to causes of action.

5. The arbitrator will close the arbitration hearing after presentation of the evidence and receipt of final briefs, which must be submitted within twenty (20) days from the final presentation of evidence. The time limit within which the award must be filed begins with the closing of the hearing.
6. The arbitrator may for good cause reopen the hearing through request of either party, at any time, before the award is made and/or legal issues in addition to causes of action.
7. The arbitrator's award must be mailed promptly to the parties, but no later than thirty (30) days after the closing of the hearing. The award will be based upon the evidence introduced at the hearing, including all logical and reasonable inferences made therefrom. Pursuant to Code of Civil Procedure Section 1296, the arbitration award must be supported by law and substantial evidence, or else it may be vacated. The arbitrator may grant any remedy that is just and equitable.

Joinder

No arbitration in which the parties elect to participate that arises out of or relates to the contract documents shall include by consolidation, joinder, or any other manner any other person or entity who is not a party to this contract unless:

1. the inclusion of such other person or entity is necessary if complete relief is to be afforded among those who are already parties to the arbitration, and
2. such other person or entity is substantially involved in a question of law or fact which is common to those who are already parties to the arbitration and which will arise in such proceedings, and
3. the written consent of the other person or entity sought to be included and of City and Contractor has been obtained for such inclusion, which consent shall make specific reference to this section; but no such consent shall constitute consent to arbitration of any dispute not specifically described in such consent or to arbitration with any party not specifically identified in such consent.

Costs and Fees

Prior to a decision being rendered in any arbitration, the parties shall split the arbitrator's fees and be responsible for the prompt payment thereof.

Conclusiveness of Judgment

Any arbitration award will be final and binding and there is no direct appeal from the award on the grounds of error in the application of the law or based upon the arbitrator's interpretation of the facts presented. The only reasons for challenging an arbitrator's award are those set forth in the Code of Civil Procedure, Section 1286.2(a), (b), (c) and/or (f), and Section 1296 (failure to base the award on applicable law and substantial evidence). If any party other than the City seeks to challenge the arbitrator's award pursuant to these Code of Civil Procedures sections, such party must post a bond in the amount of 150% of the arbitrator's award (including the award of costs and fees).

Duration

From the time any arbitration proceedings are initiated, such proceedings must be completed within six (6) months, unless (1) the amount in controversy equals or exceeds \$150,000, the arbitration must be completed within one year or (2) the arbitrator extends the completion period for good cause or based upon the stipulation of the parties. Arbitration proceedings shall be deemed initiated upon the appointment of the arbitrator.

21. HOURS FOR PERFORMANCE

Working hours for the construction project will be 8:30 a.m. to 4:30 p.m. on any Working Day. Contractor is to take into special consideration that the nature of the Work is *predominantly near residential properties*. All project Work will not disrupt or conflict with City special events as directed by the Engineer.

**CITY OF MISSION VIEJO
PROPOSAL**

**HIGHWAY SAFETY IMPROVEMENT PROGRAM (HSIP)
CITYWIDE AUDIBLE PEDESTRIAN PUSH BUTTON IMPROVEMENTS
VARIOUS LOCATIONS
CIP 23255**

TO **CITY OF MISSION VIEJO**, as AGENCY:

In accordance with AGENCY's "Notice Inviting Bids", the undersigned bidder ("BIDDER") hereby proposes to furnish all materials, equipment, tools, labor, and incidentals required for the above-stated Contract as set forth in the Plans, Specifications, and Contract Documents therefor, and to perform all Work in the manner and time prescribed therein.

BIDDER declares that this proposal, including the bid sheet, the subcontractor list, the non-collusion declaration, the Iran Contracting Act declaration, and a sufficient funds declaration ("Proposal") is based upon careful examination of the Work site, Plans, Specifications, Notice Inviting Bids, Instructions to Bidders, and other Contract Documents. If this proposal is accepted for award, BIDDER agrees to enter into the Contract with AGENCY at the unit and/or lump sum prices set forth in this Proposal. BIDDER understands that failure to enter into the Contract in the manner and time prescribed will result in forfeiture to AGENCY of the Bid Bond accompanying this proposal.

BIDDER understands that a bid is required for the entire Work, that any estimated quantities set forth in the Proposal are solely for the purpose of comparing bids, and that final compensation under the Contract will be based upon the actual quantities of Work satisfactorily Completed. It is agreed that any unit and/or lump sum prices in the Proposal include all appurtenant expenses, taxes, royalties, and fees. In the case of discrepancies in the amounts bid, unit prices shall govern over extended amounts.

BIDDER agrees and acknowledges that it is aware of the provisions of Section 3700 of the Labor Code, which requires every employer to be insured against liability for workers' compensation or to undertake self-insurance in accordance with the provisions of that code, and that the BIDDER will comply with such provisions of that code before commencing the performance of this Contract if awarded to it.

BIDDER certifies that in all previous contracts or subcontracts, all reports that may have been due under the requirements of any agency, State, or Federal equal employment opportunity orders have been satisfactorily filed, and that no such reports are currently outstanding.

BIDDER declares that the only persons or parties interested in this Proposal as principals are those named herein; that no officer, agent, or employee of the AGENCY is personally interested, directly or indirectly, in this Proposal; that this Proposal is made without connection to any other individual, firm, or corporation making a bid for the same work; and that this Proposal is in all respects fair and without collusion or fraud.

BIDDER'S INFORMATION

BIDDER certifies that the following information is true and correct:

Bidder's Name _____

Business Address _____

Telephone: () _____

E-mail _____

State Contractor's License No. and Class _____

Original Date Issued _____ Expiration Date _____

Department of Industrial Relations (DIR) Registration Number _____

The following are the names, titles, addresses, and phone numbers of all individuals, firm members, partners, joint ventures, and/or corporate officers having a principal interest in this proposal:

The dates of any voluntary or involuntary bankruptcy judgments against any principal having an interest in this Proposal are as follows:

All current and prior DBAs, alias, and/or fictitious business names for any principal having an interest in this Proposal are as follows:

Bidder's Name _____

LIST OF SUBCONTRACTORS

All Contractors (and subcontractors) must be registered with the State Division of Industrial Relations and certified to bid on Public Works contracts before bid/proposal submission. Please register at:

<https://efiling.dir.ca.gov/PWCR/ActionServlet?action=displayPWCRegistrationForm>

BIDDER proposes to subcontract certain portions of the work, as follows

Name of Subcontractor	Contractor's License #	DIR PWCR #	Address/Phone # of Office, Mill or Shop	Percent of Total Contract	Bid Items (List % of Bid Item if Portion Only)

If more space is needed to list subcontractors, please copy this page and fill out.

**CITY OF MISSION VIEJO
PUBLIC WORKS DEPARTMENT**

BIDDER'S STATEMENT OF PAST CONTRACT DISQUALIFICATIONS

The Bidder is required to state any and all instances of being disqualified, removed, or otherwise prevented from bidding on or completing any contract for construction.

1. Have you ever been disqualified from any contract?

Yes No

2. If yes, explain the circumstances:

Signature of Bidder

Printed Name of Bidder

Bidder's Company

PROPOSAL

IN WITNESS WHEREOF, Bidder executes and submits this proposal with the names, titles, hands and seals of all forenamed principals this ____ day of _____, 20__.

BIDDER

ACKNOWLEDGMENT

A notary public or other officer completing this certificate verifies only the identity of the individual who signed the document to which this certificate is attached, and not the truthfulness, accuracy, or validity of that document.

State of California
County of _____

On _____, before me, _____
(insert name and title of the officer)

personally appeared _____, who proved to me on the basis of satisfactory evidence to be the person(s) whose name(s) is/are subscribed to the within instrument and acknowledged to me that he/she/they executed the same in his/her/their authorized capacity(ies), and that by his/her/their signature(s) on the instrument the person(s), or the entity upon behalf of which the person(s) acted, executed the instrument.

I certify under PENALTY OF PERJURY under the laws of the State of California that the foregoing paragraph is true and correct.

WITNESS my hand and official seal.

Signature _____ (Seal)

AGENCY acknowledges that this proposal was received and opened at the time and in the place specified, and that it was accompanied by the required guarantee in the amount of ten percent (10%) of the total bid.

By: _____

Title _____

**CITY OF MISSION VIEJO
NON-COLLUSION AFFIDAVIT**

(To be executed by Bidder and submitted with its bid)

STATE OF CALIFORNIA)
) ss
COUNTY OF)

_____, being first duly sworn, deposes and says that he or she is
_____ *[insert title]* of _____
[insert bidder name], the party making the foregoing bid that the bid is not made in the interest of, or on behalf of, any undisclosed person, partnership, company, association, organization, or corporation; that such bid is genuine and not collusive or sham; that said bidder has not directly or indirectly induced or solicited any other bidder to put in a false or sham bid, and has not directly or indirectly colluded, conspired, connived, or agreed with any bidder or anyone else to put in a sham bid, or that anyone shall refrain from bidding; that the bidder has not in any manner, directly or indirectly, sought by agreement, communication, or conference with anyone to fix the bid price of the bidder or any other bidder, or to fix any overhead, profit, or cost element of the bid price, or of that of any other bidder, or to secure any advantage against the public body awarding the contract of anyone interested in the proposed contract; that all statements contained in the bid are true; and further, that the bidder has not, directly or indirectly, submitted his or her bid price or any breakdown thereof, or the contents thereof, or divulged information or data relative thereto, or paid, and will not pay, any fee to any corporation, partnership, company association, organization, bid depository, or to any member or agency thereof to effectuate a collusive or sham bid, and has not paid, and will not pay, any person or entity for such purpose.

Any person executing this declaration on behalf of a bidder that is a corporation, partnership, joint venture, limited liability company, limited liability partnership, or any other entity, hereby represents that he or she has full power to execute, and does execute, this declaration on behalf of the bidder.

I declare under the penalty of perjury under the laws of the State of California that the foregoing is true and correct and that this declaration is executed on _____, 20____, at _____, California.

Signed _____

Print Name

Title

ACKNOWLEDGMENT

A notary public or other officer completing this certificate verifies only the identity of the individual who signed the document to which this certificate is attached, and not the truthfulness, accuracy, or validity of that document.

State of California

County of _____

On _____, before me, _____
(insert name and title of the officer)

personally appeared _____, who proved to me on the basis of satisfactory evidence to be the person(s) whose name(s) is/are subscribed to the within instrument and acknowledged to me that he/she/they executed the same in his/her/their authorized capacity(ies), and that by his/her/their signature(s) on the instrument the person(s), or the entity upon behalf of which the person(s) acted, executed the instrument.

I certify under PENALTY OF PERJURY under the laws of the State of California that the foregoing paragraph is true and correct.

WITNESS my hand and official seal.

Signature _____ (Seal)

CITY OF MISSION VIEJO

BID BOND

HIGHWAY SAFETY IMPROVEMENT PROGRAM (HSIP)

CITYWIDE AUDIBLE PEDESTRIAN PUSH BUTTON IMPROVEMENTS

CIP 23255

(To be submitted by bidder with its bid)

KNOW ALL MEN BY THESE PRESENTS that we _____
 as "Principal/Bidder," and _____ as "Surety," are held
 and firmly bound unto City of Mission Viejo as "Agency" in the penal sum of
 _____ Dollars
 (\$ _____), for the payment of which sum well and truly to be made, we bind ourselves, our heirs, executors,
 administrators and successors, jointly and severally, firmly by these presents.

The conditions of this obligation are such that whereas the Principal/Bidder submitted to the Agency a certain Proposal,
 attached hereto and hereby made a part hereof, to enter into the written Contract for the
 _____ work of improvement and will furnish all required
 certificates of insurance and bonds as required by the Contract.

NOW THEREFORE, if said Proposal shall be rejected; or in the alternate, if said Proposal shall be accepted, and the
 Principal/Bidder shall execute and deliver a contract in the prescribed Form of Agreement, shall deliver certificates
 evidencing that the required insurance is in effect and shall execute and deliver Performance and Payment Bonds in the
 forms prescribed, and shall in all other respects perform the agreement created by the acceptance of said Proposal, then
 this obligation shall be void; otherwise, this obligation shall remain in force and effect, it being expressly understood and
 agreed that the liability of the Surety for any and all default of the Principal/Bidder hereunder shall be the amount of this
 obligation as herein stated.

The Surety, for the value received, hereby stipulates and agrees that the obligations of said Surety and its bond shall in no
 way be impaired or affected by an extension of the time within which the Agency may accept such a proposal; and said
 Surety does hereby waive notice of any such extension.

BID BOND (Page Two)

IN WITNESS WHEREOF, the above-bounded parties have executed this instrument under their several seals this _____ day of _____, 20____, the name and corporate seal of each corporate party being hereto affixed and these presents duly signed by its undersigned representative, pursuant to authority of its governing body.

ATTEST:

(Principal/Bidder) _____
(Address) _____

(By) _____
(Title) _____

NOTE: SIGNATURE OF CORPORATE OFFICIALS MUST BE NOTARIZED

ATTEST:

(Surety) _____
(Address) _____

(By) _____
(Title) _____

NOTE: SIGNATURE OF SURETY OFFICIALS MUST BE NOTARIZED

BOND APPROVED AS TO FORM:

William P. Curley III
City Attorney
City of Mission Viejo

ACKNOWLEDGMENT

A notary public or other officer completing this certificate verifies only the identity of the individual who signed the document to which this certificate is attached, and not the truthfulness, accuracy, or validity of that document.

State of California
County of _____

On _____, before me, _____
(insert name and title of the officer)

personally appeared _____, who proved to me on the basis of satisfactory evidence to be the person(s) whose name(s) is/are subscribed to the within instrument and acknowledged to me that he/she/they executed the same in his/her/their authorized capacity(ies), and that by his/her/their signature(s) on the instrument the person(s), or the entity upon behalf of which the person(s) acted, executed the instrument.

I certify under PENALTY OF PERJURY under the laws of the State of California that the foregoing paragraph is true and correct.

WITNESS my hand and official seal.

Signature _____ **(Seal)**

Bidder's Name: _____

**CITY OF MISSION VIEJO
PROPOSAL BID SHEET**

**HIGHWAY SAFETY IMPROVEMENT PROGRAM (HSIP)
CITYWIDE AUDIBLE PEDESTRIAN PUSH BUTTON IMPROVEMENTS
VARIOUS LOCATIONS
CIP 23255**

The following estimate of quantities of Work to be done and materials to be furnished are approximate only. It is given as a basis for comparison of bids and the City does not expressly or by implication agree that the actual amount of Work will correspond therewith. The City reserves the right to increase or decrease the amount of Work, or to omit portions of the Work that may be deemed necessary or expedient by the City.

Item No.	Item Description	Quantity	Unit	Unit Price	Total Amount
1*	Remove existing pedestrian push button and furnish & install new audible pedestrian push button per City specifications.	152	EA	\$	\$
2*	Furnish and install new central control unit (CCU) per City specifications.	24	EA	\$	\$

Total Bid Amount \$ _____

Total Bid Amount in Words: _____

Dollars

* Contractor is responsible during preparation of his bid to review all locations of countdown pedestrian signal heads improvements shown in these specifications and include sufficient funds in the lump sum bid item to modify existing traffic signal systems and replace any traffic signal infrastructure damaged by construction. Construction work is anticipated to be completed during hours with the least amount of impacts to pedestrian, bicycle and vehicular traffic (i.e., off-peak hours such as weekdays 8:30AM - 4:30 PM with the exception hours during school arrival and dismissal times or the presence of crossing guards).

The City will determine the low bidder in the manner stated in the Notice Inviting Bids. Contractor agrees that his bid, or any bid item, will not be invalidated by such determination.

In case of a variation between the unit price and the totals shown by Bidder, the unit price will be considered to be the bid.

The Contractor shall complete this Proposal Bid Sheet for use only by Agency for comparison of bids and compensation to the Contractor for this project. The estimated quantities and itemized descriptions listed in the Proposal Bid Sheets are supplied to give an indication of the general size of the work. Unit prices are intended to be the basis additions, deletions or substitutions to the work, if required. The accuracy of the estimated quantities is not guaranteed. The Bidder shall make his own estimate from information included in the Contract Documents and from field inspections. **The Work to be performed shall include, but not be limited to, the items described. The bid shall include the furnishing of labor, services, tools, equipment, materials, appurtenances, and incidentals necessary to install or Complete all Work contemplated per the plans and specifications. Any Work required per the plans and specifications for which there is no specific bid item shall be considered as included in the various bid items of Work (unless listed by Bidder under miscellaneous elements) and no additional compensation will be allowed therefor.** The City reserves the right to increase or decrease the amount of any class or portion of the Work, or to omit portions of the Work that may be deemed necessary or expedient by the City.

NOTE: The City places special emphasis on the presence of the Contractor's representative at all times while Work is being performed. A representative from the **prime** Contractor shall be present at **all** times. The Contractor must include this cost in its bid. Failure to have the prime Contractor's representative present in accordance with Section 7-6 of the Standard Specifications shall result in the deduction of \$1,000 per day from progress payments to the Contractor. The unit quantities listed in the Proposal Bid Sheet are approximate only. Upon Completion of construction, if the actual quantities show either an increase or decrease from the quantities given in the Proposal Bid Sheet, the Contract Unit Prices will prevail subject

to the provisions of Subsection 3-2.2.1 (unless otherwise specified). Payment will not be made for materials wasted or disposed of in a manner not called for under the Contract; this includes rejected material not unloaded from vehicles, material rejected after it has been placed and material placed outside of the Plan lines. No compensation will be allowed for disposing of rejected or excess material.

Proposals must be accompanied by a proposal guarantee consisting of a certified check or bid bond payable to the AGENCY in the amount of ten percent (10%) of the total amount bid.

Bidder's Name _____

Telephone No. _____

Bidder shall signify receipt of all Addenda here, if any:

<u>Addendum No.</u>	<u>Date Received</u>	<u>Bidder's Signature</u>
_____	_____	_____
_____	_____	_____
_____	_____	_____
_____	_____	_____

**CITY OF MISSION VIEJO
CONTRACT AGREEMENT**

**HIGHWAY SAFETY IMPROVEMENT PROGRAM (HSIP)
CITYWIDE AUDIBLE PEDESTRIAN PUSH BUTTON IMPROVEMENTS
VARIOUS LOCATIONS
CIP 23255**

THIS CONTRACT AGREEMENT is made and entered into for the above-stated project this _____ day of _____, 20____, BY AND BETWEEN THE **CITY OF MISSION VIEJO**, as City and _____ as CONTRACTOR.

WITNESSETH that CITY and CONTRACTOR have mutually agreed as follows:

Article I

The contract documents for the aforesaid project shall consist of the Notice Inviting Bids, Instructions to Bidders, Proposal, General Specifications, Special Provisions in accordance with the Standard Specifications for Public Works Construction, Faithful Performance Bond, Labor and Material Bond, and all referenced specifications, details, Standard Plans and appendices, including all applicable State and Federal requirements; together with this Contract Agreement and all required bonds, insurance certificates, permits, notices and affidavits; and also including any and all addenda or supplemental agreements clarifying, amending or extending the work contemplated as may be required to insure its completion in an acceptable manner (collectively all the foregoing shall be referenced as the "Contract Documents"). All of the provisions of said contract documents are made a part hereof as though fully set forth herein.

Article II

For and in consideration of the payments and agreements to be made and performed by CITY, CONTRACTOR agrees to furnish all materials and perform all work required for the above stated project and to fulfill all other obligations as set forth in the aforesaid Contract Documents.

Article III

CONTRACTOR agrees to receive and accept the prices set forth in the proposal as full compensation for furnishing all materials, performing all work and fulfilling all obligations hereunder. Said compensation shall cover all expenses, losses, damages, and consequences arising out of the nature of work during its progress or prior to its acceptance, including those for well and faithfully completing the work and the whole hereof in the manner and time specified in the aforesaid Contract Documents; and also including those arising from actions of the elements, unforeseen difficulties or obstructions encountered in the prosecution of the work, suspension or discontinuance of the work, and all other unknowns or risks of any description connected with the work.

Article IV

CITY hereby promises and agrees to employ, and does hereby employ, CONTRACTOR to provide the materials, do the work and fulfill the obligations according to the terms and conditions herein contained and referred to, for the prices aforesaid, and hereby contracts to pay the same at the time, in the manner and upon the conditions set forth in the Contract Documents.

The total amount of this contract shall not exceed _____ Dollars (\$_____). CONTRACTOR shall not be compensated for any services rendered in connection with its performance of this agreement which are in addition to those set forth herein, unless such additional services are authorized in advance and in writing by the City Council, or if pursuant to its authority, the City Manager, or his or her designee. CONTRACTOR shall be compensated for any additional services in the amounts and in the manner as agreed to by the City Manager or City representative and CONTRACTOR at the time City's written authorization is given to CONTRACTOR for the performance of said services. The City Manager may approve additional work not to exceed 15% of the contract amount approved by City Council or \$30,000 whichever is less. Any additional work in excess of this amount shall be approved by the City Council.

ACKNOWLEDGMENT

A notary public or other officer completing this certificate verifies only the identity of the individual who signed the document to which this certificate is attached, and not the truthfulness, accuracy, or validity of that document.

State of California
County of _____

On _____, before me, _____
(insert name and title of the officer)

personally appeared _____,
who proved to me on the basis of satisfactory evidence to be the person(s) whose name(s) is/are subscribed to the within instrument and acknowledged to me that he/she/they executed the same in his/her/their authorized capacity(ies), and that by his/her/their signature(s) on the instrument the person(s), or the entity upon behalf of which the person(s) acted, executed the instrument.

I certify under PENALTY OF PERJURY under the laws of the State of California that the foregoing paragraph is true and correct.

WITNESS my hand and official seal.

Signature _____ **(Seal)**

Premium \$ _____
Premium will be based on final contract amount.

Bond No.: _____

**CITY OF MISSION VIEJO
FAITHFUL PERFORMANCE BOND**

**HIGHWAY SAFETY IMPROVEMENT PROGRAM (HSIP)
CITYWIDE AUDIBLE PEDESTRIAN PUSH BUTTON IMPROVEMENTS
VARIOUS LOCATIONS
CIP 23255**

THAT, WHEREAS, the City of Mission Viejo, State of California ("City") entered into a contract dated _____
_____, 20____, hereinafter called "Contract," with _____
_____, [insert name and address of contractor], hereinafter called "Principal," for the
work described as follows:

Install countdown pedestrian signal head module devices and all appurtenant work at various
signalized intersection locations; and

WHEREAS, the said Principal is required under the terms of said Contract to furnish a bond for the faithful
performance of said Contract.

NOW, THEREFORE, WE, the Principal and _____, duly authorized to transact business
under the laws of the State of California, as Surety, hereinafter called "Surety," are held and firmly bound unto the City
of Mission Viejo in the penal sum of _____ Dollars
(\$ _____), lawful money of the United States, said sum being not less than one hundred percent
(100%) of the estimated amount payable by the said City of Mission Viejo under the terms of the Contract for the
payment of which we bind ourselves, our heirs, executors, administrators, successors, and assigns, jointly and
severally, firmly by these presents.

THE CONDITION OF THIS OBLIGATION is such that, if said Principal, its heirs, executors, administrators,
successors, or assigns, shall in all things stand to, abide by, and well and truly keep and perform the covenants,
conditions, and agreements in the said Contract, and in any alteration thereof made as therein provided, on its part to
be kept and performed, at the time and in the intent and meaning, and shall indemnify and save and hold harmless the
City of Mission Viejo, its officers, officials, employees, agents and volunteers as therein stipulated, then this obligation
shall become null and void; otherwise it shall be and remain in full force and virtue.

As part of the obligation secured hereby and in addition to the face amount specified, costs and reasonable
expenses and fees shall be included, including reasonable attorney's fees incurred by the City of Mission Viejo in
successfully enforcing the obligation, all to be taxed as costs and included in any judgment rendered.

FAITHFUL PERFORMANCE BOND (Page Two)

The Surety hereby stipulates and agrees that no change, extension of time, alteration, or addition to the terms of the Contract, or to the Work to be performed thereunder, or to the plans and specifications accompanying the same, shall in any way affect its obligations on this bond, and it does hereby waive notice of any such change, extension of time, alteration, or addition to the terms of the Contract, or to the Work, or to the plans and specifications.

IN WITNESS WHEREOF, this instrument has been duly executed by the Principal and Surety above named, on _____, 20__.

(Seal)

SURETY:

By: _____

Name: _____

Title: _____

(Seal)

PRINCIPAL:

By: _____

Name: _____

Title: _____

By: _____

Name: _____

Title: _____

APPROVED AS TO FORM:

William P. Curley III
City Attorney
City of Mission Viejo

Premium \$ _____
Premium will be based on final contract amount.

Bond No.: _____

**CITY OF MISSION VIEJO
LABOR AND MATERIAL PAYMENT BOND**

**HIGHWAY SAFETY IMPROVEMENT PROGRAM (HSIP)
CITYWIDE AUDIBLE PEDESTRIAN PUSH BUTTON IMPROVEMENTS
VARIOUS LOCATIONS
CIP 23255**

KNOW ALL MEN BY THESE PRESENTS:

THAT, WHEREAS, the City of Mission Viejo ("City") has awarded to _____
[insert name and address of contractor], hereinafter called "Contractor," a Contract for the Work described as follows:

Install countdown pedestrian signal head module devices and all appurtenant work at various signalized intersection locations; and

WHEREAS, said Contractor is required by the provisions of Sections 3247-3252 of the Civil Code to furnish a bond in connection with said Contract, as hereinafter set forth.

NOW, THEREFORE, WE, the undersigned Contractor as Principal, and _____, duly authorized to transact business under the laws of the State of California, as Surety, hereinafter called "Surety," are held and firmly bound unto the City of Mission Viejo, California, and all contractors, subcontractors, laborers, materialmen, and other persons employed in the performance of the aforesaid Contract and referred to in Title 15 of the Civil Code, in the penal sum of _____ Dollars (\$ _____), lawful money of the United States, said sum being not less than one hundred percent (100%) of the estimated amount payable by the said City of Mission Viejo under the terms of the Contract for the payment of which we bind ourselves, our heirs, executors, administrators, successors, and assigns, jointly and severally, firmly by these presents.

THE CONDITION OF THIS OBLIGATION is such that, if said Principal, its heirs, executors, administrators, successors and assigns, or subcontractors, shall fail to pay for any materials, provisions, provender or other supplies, or teams, implements or machinery, used in, upon, for or about the performance of the Work under the Contract to be done, or for any work or labor thereon of any kind or for amounts due under the Unemployment Insurance Code with respect to such work or labor, as required by the provisions of Chapter 7 of Title 5 of Part 4 of Division 3 of the Civil Code, and provided that the claimant shall have complied with the provisions of said Civil Code, the Surety shall pay for the same in an amount not exceeding the sum specified in this bond; otherwise, the above obligation shall be void. In case suit is brought upon this bond, the Surety will pay costs and reasonable expenses and fees, including reasonable attorneys' fees to be fixed by the Court.

PAYMENT BOND (Page Two)

This bond shall inure to the benefit of any and all persons, companies, and corporations entitled to file claims under Sections 3181 of the Civil Code, so as to give a right of action to them or their assigns in any suit brought upon this bond, and shall also cover payment for any amounts required to be deducted, withheld, and paid over to the Employment Development Department from the wages of employees of the Contractor or its subcontractors pursuant to Section 13020 of the Unemployment Insurance Code.

The Surety hereby stipulates and agrees that no change, extension of time, alteration, or addition to the terms of the Contract, or to the Work to be performed thereunder, or to the plans or specifications accompanying the same, shall in any way affect its obligations on this bond. The Surety hereby waives notice of any such change, extension of time, alteration or addition to the terms of the Contract, or to the Work to be performed thereunder, or to the plans or specifications accompanying the same.

IN WITNESS WHEREOF, this instrument has been duly executed by the Principal and Surety above named, on _____, 20__.

(Seal)

SURETY:

By: _____

Name: _____

Title: _____

(Seal)

PRINCIPAL:

By: _____

Name: _____

Title: _____

By: _____

Name: _____

Title: _____

APPROVED AS TO FORM:

William P. Curley III
City Attorney
City of Mission Viejo

**CITY OF MISSION VIEJO
COMPENSATION INSURANCE CERTIFICATE
HIGHWAY SAFETY IMPROVEMENT PROGRAM (HSIP)
CITYWIDE AUDIBLE PEDESTRIAN PUSH BUTTON IMPROVEMENTS
VARIOUS LOCATIONS
CIP 23255**

Pursuant to Section 1861 of the State Labor Code (amended by Stats. 1979, C.373, p. 1343), before beginning the Work, the Contractor shall furnish to the City Engineer a certificate of insurance for all persons whom he may employ directly or through subcontractors in carrying out the work specified herein, in accordance with the laws of the State of California. Such insurance shall be maintained in full force and effect during the period covered by this contract.

Before beginning the Work, the Contractor shall furnish to the City Engineer a certificate of insurance as proof that he has taken out full compensation insurance for all persons whom he may employ directly or through subcontractors in carrying out the work specified herein, in accordance with the laws of the State of California. Such insurance shall be maintained in full force and effect during the period covered by this contract.

Contractor, prior to commencing work, shall sign and file with the City of Mission Viejo a certification as follows:

I am aware of the provisions of Section 3700 of the Labor Code which requires every employer to be insured against liability for Worker's Compensation or to undertake self-insurance in accordance with the provisions of that Code, and I will comply with such provisions before commencing the performance of the work of this contract.

CONTRACTOR
By: _____
Title: _____
Date: _____

Section 3700 of the State Labor Code reads as follows:

"Every employer except the State shall secure the payment of compensation in one or more of the following ways:

- (a) By being insured against liability to pay compensation in one or more insurers duly authorized to write compensation insurance in the state.
- (b) By securing from the Director of Industrial Relations a certificate of consent to self-insure, which may be given upon furnishing proof satisfactory to the Director of Industrial Relations of ability to self-insure and to pay any compensation that may become due to his employee."

(Amended by Stats, 1978, c. 1379, p. 4571)

Compensation Insurance Certificate
To be Submitted with Contract Agreement

**CITY OF MISSION VIEJO
GENERAL SPECIFICATIONS**

**HIGHWAY SAFETY IMPROVEMENT PROGRAM (HSIP)
CITYWIDE AUDIBLE PEDESTRIAN PUSH BUTTON IMPROVEMENTS
VARIOUS LOCATIONS
CIP 23255**

SCOPE OF WORK

The Work to be done consists of furnishing all permits, licenses, testing, materials, equipment, tools, labor and incidentals as required by the Contract Documents to construct the above-stated project, as well as any other duties or obligations of Contractor under the Contract Documents.

The general items of Work include traffic signal equipment upgrades. The improvements include, but are not limited to, site mobilization, removing existing pedestrian push button modules, installing new pedestrian push button modules, and all appurtenant work.

LOCATION OF WORK

The general locations and limits of the Work are on existing traffic signals and approximately twenty-four (24) locations for audible pedestrian push button module installations in the City of Mission Viejo.

TIME OF COMPLETION

The Contractor shall Complete all Work in every detail within **fifty (50) working days** (as defined in the Greenbook Standard Specifications; see below) after the date of the Notice to Proceed, exclusive of maintenance periods.

PERFORMANCE OF AT LEAST 50% OF THE WORK

Per Standard Specifications Section 2-3.2, the Contractor must perform at least 50% of the Work itself.

TRAFFIC REQUIREMENTS

The Contractor shall provide delineation in accordance with the WATCH Manual or the latest edition of California Manual of Uniform Traffic Control Devices Guidelines or as directed by the Engineer. The Contractor shall only be permitted to close the shoulder of the roadway or travel lanes in order to facilitate construction of the improvements.

UTILITY REQUIREMENTS

The Contractor is advised of the existence of the utility notification service provided by UNDERGROUND SERVICE ALERT (USA). USA member utilities will provide the Contractor with the precise locations of their substructures in the construction area when the Contractor gives at least 48 hours' notice to the Underground Service Alert by calling 1-800-422-4133.

The Contractor shall notify the following agencies at least 48 hours in advance of excavating around any of their structures. The utility companies listed below can be contacted as indicated.

AT&T California

3939 East Coronado Street, Second Floor
Anaheim, California 92807
Valentina Gipson 714-618-9132
vk3921@att.com

Cox Communications

29947 Avenida de las Banderas
Rancho Santa Margarita, California 92688
Sina Muckenfuss 949-546-2485
sina.muckenfuss@cox.com

El Toro Water District

24251 Los Alisos
Lake Forest, California 92630
Brian Miller 949-837-7050 x224
bmiller@etwd.com

Moulton-Niguel Water District

26161 Gordon Road
Laguna Hills, California 92653
Steve Merk 949-425-3538
smerk@mnwd.com

Santa Margarita Water District
26111 Antonio Parkway
Rancho Santa Margarita, California 92688
Jeff MacDonnell 949-459-6504
jeffm@smwd.com

Metropolitan Water District of Southern California
Richard Ford
714-577-5088

San Diego Gas & Electric
662 Camino De Los Mares, SD1421
San Clemente 92673
Dolphus D. Davis 949-369-4721
dddavis@semprautilities.com

Southern California Edison
14155 Bake Parkway
Irvine, California 92619
Todd Tate 949-458-4419
todd.tate@sce.com

Southern California Gas Company
1919 South State College Boulevard, SC8320
Anaheim, California 92806
Brad Morrison 714-634-3061
bmorrison@semprautilities.com

City of Mission Viejo
Public Services Department
27204 East La Paz Road
Mission Viejo, California 92692
949-470-3064

The California Public Utilities Commission mandates that, in the interest of public safety, mainline gas valves be maintained in a manner to be readily accessible and in good operating condition. The Contractor shall notify the Southern California Gas Company's Headquarters Planning Office at 714-369-0680, at least two (2) working days prior to the start of construction.

The Contractor shall exercise extreme care to protect all existing utilities in place whether shown on the plans or not, and shall assume full responsibility for all damage resulting from its operations. The Contractor shall coordinate with each utility company as to the requirements and methods for protection of their facilities during the construction period and shall be responsible for preparation and processing of any required plans or permits. The Contractor shall assume full responsibility to maintain uninterrupted service for all utilities.

By submitting a bid, the Contractor acknowledges the above-referenced utility work to be done in conjunction with this project. The Contractor shall schedule its work and conduct its operations so as to permit access and time for the required utility work to be accomplished during the progress of the work.

The Contractor shall coordinate with each utility company as to the extent of required work and the time required to do so. The Contractor shall include this time in its schedule. Payment for the above, if any, shall be deemed as included in the items of work as shown on the proposal bid sheet and no additional compensation will be allowed.

FLOW AND ACCEPTANCE OF WATER

It is anticipated that storm, surface, or other waters will be encountered at various times during the work herein contemplated. The Contractor, by submitting a bid, acknowledges that he has investigated the risk arising from such waters and has prepared his bid accordingly; and Contractor submitting a bid assumes all said risk.

The Contractor shall conduct his operations in such a manner that storm or other existing waters may proceed uninterrupted along their existing street or drainage courses. Diversions of water for short reaches to protect construction in progress will be permitted if public and/or private properties, in the opinion of the Engineer, are not subject to probability of damage. The Contractor shall obtain written permission from the applicable public agency or property owner before any diversion of water outside of public right-of-way will be permitted.

REMOVAL OF WATER

The Contractor shall provide and maintain at all times during construction ample means and devices to promptly remove and properly dispose of all water entering the excavations or other parts of the work. No concrete footing or floor shall be laid in water, nor shall water be allowed to rise over them until the concrete or mortar has set. Dewatering for the structures and pipelines shall commence when ground water is first encountered and shall be continuous until such time as water can be allowed to rise in accordance with the above paragraph. Dewatering shall be accomplished by well points or some other method which will insure a dry hole and preservation of final lines and grade of the bottoms of excavation, all subject to the approval of the Engineer.

Disposal of water from dewatering operations shall be the sole responsibility of the Contractor. Disposal methods shall conform to the Porter-Cologne Water Quality Control Act of 1974, the Federal Water Pollution Control Act Amendments of 1972, and the California Administrative Code, Title 23, Chapter 3.

Full compensation of dewatering shall be considered as included in the contract prices paid for the related items of work, and no additional compensation will be allowed therefore.

TRENCH SAFETY AND SHORING EXCAVATION

In accordance with Section 6500 of the Labor Code, the Contractor is required to obtain a permit from the Division of Industrial Safety for any trench or excavation which is five feet (5') or more in depth and into which a person is required to descend.

The Contractor shall furnish all labor, equipment, and materials required to design, construct, and remove all sheeting, shoring, and bracing or other equivalent method of support of this project.

Excavation for any trench five feet (5') or more in depth shall not begin until the Contractor has received approval from the Engineer of the Contractor's detailed plan for worker protection from hazards of caving ground. Such plan shall be submitted at least five (5) days before the Contractor intends to begin excavation and shall show the details of the design of shoring, bracing, sloping, or other provisions to be made for worker protection during excavation. No such plan shall allow the use of shoring, sloping, or a protective system less effective than required by Construction Safety Orders of the Division of Industrial Safety; and if such plan varies from the shoring system standards established by the Construction Safety Orders, the plan shall be prepared and signed by the Engineer who is registered as a Civil or Structural Engineer in the State of California.

Prior to beginning of excavations requiring shoring, the Contractor shall designate in writing to the Engineer someone whose responsibility it is to supervise the project safety measures and someone whose responsibility it is to supervise the installation and removal of sheeting, shoring and bracing.

In addition to shoring the excavations in accordance with the minimum requirements of Industrial Safety Orders, it shall be the Contractor's responsibility to provide any and all additional shoring required to support the sides of the excavation against the effects of load which may exceed those desired by using the criteria set forth in the Industrial Safety Orders. The Contractor shall be solely responsible for any damages which may result from his failure to provide adequate shoring of the excavation under any and all of the conditions of loading which may exist or which may arise during construction of the project.

The Contractor shall include in his bid all costs for the above requirements. Full compensation for sheeting, shoring, bracing, and all other things necessary shall be considered as included in the appropriate bid items of work, and no additional allowance will be made therefore.

STANDARD SPECIFICATIONS

The Standard Specifications of the City are contained in the most recent edition of the *Standard Specifications for Public Works Construction*, Latest Edition, including all supplements as written and promulgated by the Joint Cooperative Committee of the Southern California District of the Associated General Contractors of California. Copies of these Standard Specifications (the "Greenbook") are available from the publisher:

Building News, Incorporated
1612 South Clementine Street, Suite A
Anaheim, California 92802
714-517-0970

The section numbers of the City's General Provisions and Special Provisions coincide with those of the *Standard Specifications for Public Works Construction*. Only those sections requiring amendment or elaboration, or specifying options, are called out.

Where the plans or specifications describe portions of the work in general terms, but not in complete detail, it is understood that the item is to be furnished and installed complete and in place and that only the best general practice is to be used. Unless otherwise specified, the Contractor shall furnish all labor, materials, tools, equipment, and incidentals, and perform all the work, involved in executing the contract.

WAGE RATES AND LABOR CODE REQUIREMENTS

Wage Rates

The Contractor and all Subcontractors shall be required to adhere to the general prevailing rate of per diem wages as determined and published by the State Director of the Department of Industrial Relations, pursuant to Sections 1770,

1773, and 1773.2 of the California Labor Code. Copies of these rates and the latest revisions thereto are on file in the Office of the Secretary of the Board of Directors and are available for review upon request.

Attention is directed to the provisions of Sections 1774, 1775, 1776, 1777.5 and 1777.6 of the State Labor Code. Sections 1774 and 1775 require the Contractor and all Subcontractors to pay not less than the prevailing wage rates to all workmen employed in the execution of the contract and specify forfeitures and penalties for failure to do so. The minimum wages to be paid are those determined by the State Director of the Department of Industrial Relations. Section 1776 requires the Contractor and all Subcontractors to keep accurate payroll records, specifies the contents thereof, their inspection and duplication procedures and certain notices required of the Contractor pertaining to their location.

Apprentices

Section 1777.5 requires the Contractor or Subcontractor employing tradesmen in any apprentice-able occupation to apply to the Joint Apprenticeship Committee nearest the site of the public works project which administers the apprenticeship program in that trade for a certificate of approval. The certificate will also fix the ratio of apprentices to journeymen to be used in the performance of the contract.

The Contractor is required to make contributions to funds established for the administration of apprenticeship programs if he employs registered apprentices or journeymen in any apprentice-able trade and if other Contractors on the public work site are making such contributions.

Information relative to apprenticeship standards, contributions, wage schedules, and other requirements may be obtained from the State Director of Industrial Relations or from the Division of Apprenticeship Standards.

CLAYTON ACT AND CARTWRIGHT ACT

Section 4551 of the State Government Code specifies that in executing a public works contract with the City to supply goods, services, or materials, the Contractor or Subcontractors offer and agree to assign to the City all rights, title and interest in and to all causes of action it may have under Section 4 of the Clayton Act (15 USC Section 15) or under the Cartwright Act (Chapter 2 commencing with Section 16700) of Part 2 of Division 7 of the Business and Professional Code arising from purchase of goods, services, or materials pursuant to the contract or subcontract. This assignment shall become effective when the City tenders final payment to the Contractor without further acknowledgment by the parties.

SUBSTITUTION OF SECURITIES

In conformance with the State of California Government Code Chapter 13, Section 4590, the Contractor may substitute securities for any moneys withheld by the City to ensure performance under the contract.

At the request and expense of the Contractor, securities equivalent to the amount withheld shall be deposited with the City or with a State- or Federally-chartered bank as the escrow agent who shall pay such moneys to the Contractor upon notification by City of Contractor's satisfactory completion of the contract. The form for this escrow agreement, as required by Public Contract Code Section 22300, may be obtained from the City Attorney's office.

The type of securities deposited and the method of release shall be approved by the City Attorney's office.

WATER POLLUTION CONTROL (NPDES COMPLIANCE)

The City of Mission Viejo in conformance with the City's National Pollutant Discharge Elimination System (NPDES) Permit, is dedicated to the elimination/reduction of water pollution as a result of construction projects. The Contractor shall comply with the items described in this section and construct those facilities as specified by these Contract Documents, as required by law, or as directed by the Engineer, as necessary to eliminate/reduce water pollution. Said items are intended to provide prevention, control, and abatement of water pollution into storm drain systems, streams, oceans, and other bodies of water as a result of the Contractor's operations. These items are supplemental to those required of the Contractor in Section 7-8 "Project Site Maintenance" of the Standard Specifications for Public Works Construction.

1. Concrete and Mortar Products:

The Contractor shall prevent or reduce the discharge of pollutants into stormwater or stormwater systems from concrete waste by conducting washouts at appropriate off-site locations, performing on-site washouts in a designated area, and providing appropriate training for employees and subcontractors.

The Contractor shall store and mix dry and wet materials either off-site or under cover, away from drainage areas.

For washout of concrete trucks, the Contractor shall provide appropriate off-site locations or designated contained areas at least fifty feet (50') away from storm drains, open ditches, streets, or streams.

The Contractor shall prevent run-off from designated washout areas by constructing a temporary pit or bermed area large enough to handle all produced liquid and solid waste. When concrete sets, break up and dispose of concrete in construction fills per direction of the soils engineer or dispose of it as solid waste and/or recycle.

The Contractor shall inform concrete suppliers and subcontractors of the designated washout locations and disposal sites for concrete and mortar products and shall be responsible for ensuring that all workers use it appropriately.

2. Construction Water:

The Contractor shall reduce or eliminate excessive construction water that may cause erosion and carry pollutants from the site. In addition, the Contractor shall:

1. Store construction water in leak-proof tanks located away from drainage systems.
2. Use construction water conservatively.
3. Whenever possible, dispose of excess water on-site, by allowing it to soak into the ground.

3. Saw-cutting Water Runoff:

Saw-cutting water runoff contains pollutants that must be contained and disposed of properly. The Contractor shall:

1. Prevent saw-cut water runoff from entering catch basins, manholes, and storm drains.
2. Direct water into a temporary pit and dispose of the water by vacuuming the water into a truck and removing the water from the site.
3. Place drip pans or absorbent materials under saw-cutting equipment when not in use.
4. Clean up spills with absorbent materials rather than burying. Dispose of absorbent material properly.

4. Housekeeping/Cleanup

The Contractor shall prevent pollution of stormwater from cleanup and disposal operations by using good housekeeping methods. When fluids or dry materials spill, cleanup should be immediate, thorough, and routine. The Contractor shall never attempt to "wash them away" with water, or bury them. The Contractor shall report significant spills to the appropriate spill response agencies immediately. The Contractor shall recognize that different types of materials have different disposal requirements and follow appropriate practices. The Contractor shall confine non-hazardous debris to dumpsters, covered at night or during wet weather, and take the debris to a landfill for recycling or disposal. The Contractor shall handle hazardous debris in accordance with specific laws and regulations and dispose of them properly. A separate permit may be required. Common hazardous debris found on construction sites are: Liquid residues from paints, thinners, solvents, glues, and cleaning fluids, leaching agents from lumber such as formaldehyde, arsenic, copper, creosote and chromium, motor oil, gear oil, antifreeze fluids, brake fluids, etc., and unused pesticides.

5. Sanitary Waste Management:

The Contractor shall prevent the discharge of sanitary waste into stormwater systems by providing convenient, properly located, well-maintained facilities. The Contractor shall hire a licensed portable sanitary facility leasing company, which will clean the facilities regularly and keep them in good working order. The Contractor shall make sure that portable sanitary facilities are located on relatively level ground away from traffic areas, drainage courses, and storm drain courses and storm drain inlets. The Contractor shall regularly inspect the facilities for any leaks, and have defective units replaced.

6. Vehicle and Equipment Management:

The Contractor shall use and maintain construction vehicles and equipment in a manner that prevents leaks and spills of fluids, contains wash waters, and controls off-site tracking. The Contractor shall not allow leaking vehicles and equipment on-site and shall inspect equipment and vehicles frequently for leaks and repair them immediately. The Contractor shall clean up spills and leaks promptly with absorbent materials, and shall not flush said spills with water.

The Contractor shall fuel, maintain, and repair vehicles and equipment off-site whenever possible and on-site only in designated areas. The Contractor shall prevent run-on and run-off from designated areas and provide cover as well as containment devices as necessary.

The Contractor shall wash vehicles and equipment on-site in designated, contained areas, allowing wash waters to infiltrate into the ground. The Contractor shall use phosphate-free, biodegradable soaps, and limit steam cleaning to confined areas only.

When not in use, the Contractor shall store equipment and vehicles in designated, contained areas and place drip pans and absorbent material under stored equipment that is prone to leaking and dripping (e.g., paving equipment).

If the Contractor must drain and replace motor oil, radiator coolant, or other fluids on-site, use drip pans or drop cloths to catch drips and spills. The Contractor shall collect all spent fluids, store in separate containers, and recycle whenever possible. Note: For recycling purposes, such liquids must not be mixed with other fluids. Non-recycled fluids generally must be disposed of as hazardous waste.

Except as otherwise provided for in the Standard Specifications or elsewhere in these Special Provisions, full compensation for conforming to the requirements of this section including furnishing all labor, tools, equipment, and materials necessary for doing the work, shall be considered as included in the prices paid for the various contract items of work and no additional compensation will be allowed therefore.

NOTE: The City of Mission Viejo is a co-permittee with the County of Orange for the water discharge from the San Diego Regional Water Quality Control Board. The Contractor will be held accountable and should make himself aware of all municipal activities procedures as part of the NPDES permit and program.

**CITY OF MISSION VIEJO
SPECIAL PROVISIONS**

**HIGHWAY SAFETY IMPROVEMENT PROGRAM (HSIP)
CITYWIDE AUDIBLE PEDESTRIAN PUSH BUTTON IMPROVEMENTS
VARIOUS LOCATIONS
CIP 23255**

These Special Provisions amend the Standard Specifications as indicated and take precedence over the General Specifications and Standard Specifications (see revised order of precedence, below [Section 3-7.2]).

PART I GENERAL PROVISIONS

SECTION 1 TERMS, DEFINITIONS, ABBREVIATIONS AND SYMBOLS

1-2 TERMS AND DEFINITIONS. [Add the following]

The definitions in this section apply throughout the Contract Documents.

Agency	City of Mission Viejo
Board	City Council
Caltrans	California Department of Transportation
City	City of Mission Viejo
County	County of Orange
Engineer	City Engineer
Federal	United States of America
Inspector	Inspector for the Agency (or his designee)
State	State of California

Change Order [Add the following sentence to the definition.] If signed by the Agency and Contractor, and approved by the Board (or approved by the City Manager if changes cumulatively total less than 15% of the Contract price or \$30,000, whichever is less), the Change Order qualifies as a Supplemental Amendment.

Completion and Complete Statutory definitions of "Completion" and "Complete" shall apply for those statutory purposes (for example, see Public Contract Code Section 7107 for release of retention, and Civil Code Section 9200 for stop payment notices and notice of completion). For all other purposes, including accrual of liquidated damages, claims, and warranties, "Completion" and "Complete" mean the point in the Work where (1) Contractor has fully and correctly performed all Work in all parts and requirements, including corrective and punch list work, and (2) City's representatives have conducted a final inspection that confirmed this performance. Substantial, or any other form of partial or non-compliant, performance shall not constitute "Completion" or "Complete."

Supplemental Agreement [Replace the definition with the following.] A written amendment of the Contract Documents signed by the Agency and the Contractor, and approved by the Board (or approved by the City Manager if changes cumulatively total less than 15% of the Contract price or \$30,000, whichever is less), including but not limited to a Change Order.

Working Day [Add the following]
The Contractor's activities shall be confined to the hours between 8:30 a.m. and 4:30 p.m. on Working Days, Monday through Friday, excluding holidays.

Deviation from these hours will not be permitted without the prior consent of City, except in emergencies involving immediate hazard to persons or property. In the event of either a requested or emergency deviation, inspection service fees will be charged against the Contractor. The service fees will be calculated at overtime rates, including benefits, overhead, and travel time. The service fees will be deducted from any amounts due the Contractor.

1-7 AWARD AND EXECUTION OF CONTRACT [Replace with the following]

1-7.1 General. [Replace with the following]

Within ten (10) working days after the date of the Notice to Award, the Contractor shall execute and return the following contract documents to the Agency:

- Contract Agreement
- Faithful Performance Bond
- Payment Bond
- Proof of Insurance, including Policies, Endorsements, and a Public Liability and Property Damage Insurance Certificate
- Workers' Compensation Insurance Certificate

Failure to comply with the above will result in annulment of the award and forfeiture of the Proposal Guarantee. The Contract Agreement shall not be considered binding upon the Agency until executed by the authorized Agency officials.

A corporation to which an award is made may be required, before the Contract Agreement is executed by the Agency, to furnish evidence of its corporate existence, of its right to enter into contracts in the State of California, and that the officers signing the contract and bonds for the corporation have the authority to do so.

1-7.2 CONTRACT BONDS [Add the following]

The Faithful Performance Bond will remain in effect until actions against Contractor, including those for patent and latent deficiencies, may no longer be timely filed, including but not limited to the 10-year period of Code of Civil Procedure Section 337.15.

SECTION 2 SCOPE OF THE WORK

2-1 WORK TO BE DONE [Add the following to the end of the paragraph]

Contractor shall expeditiously perform all changes in the Work as directed by Agency. See Section 2-7 regarding changes in the Work.

If Contractor believes that acts or omissions of City (including but not limited to City-caused delay) have prevented Contractor from performing the Work as required by the Contract Documents and Contractor intends to rely on City's acts or omissions and Civil Code Section 1511(1) as reasons to excuse Contractor's nonperformance or to support, among other things, Contractor's requests for time extensions (see Section 2-10, below), Contractor shall provide written notice of the excuse within five (5) days of the City's acts or omissions. If Contractor fails to timely submit the written notice, Contractor shall have waived any right to later rely on the acts or omissions as a defense to Contractor's nonperformance or as the basis for a time extension, regardless of the merits of the defense or time extension, as Contractor will not have satisfied a condition precedent or exhausted administrative remedies. Contractor acknowledges that these written notices are of critical importance to the City's Project management of the Work and Project and the mitigation of costs and delays to the Work and Project.

2-2 PERMITS [Replace the first sentence with the following]

Prior to the start of any Work, the Contractor shall take out and pay for the applicable Agency permits and make arrangements for Agency inspections. The Contractor and all subcontractors shall each obtain any and all other permits, licenses, inspections, certificates, or authorizations required by any governing body or public utility.

2-5 CONTRACTOR'S EQUIPMENT AND FACILITIES [Add the following]

2-5.1 General [Replace the first paragraph with the following]

A noise level limit of 86 dBA at a distance of fifty feet (50') shall apply to all construction equipment on or related to the job, whether owned by the Contractor or not. The use of excessively loud warning signals shall be avoided except in those cases required for the protection of personnel.

2-7 CHANGES INITIATED BY THE AGENCY

2-7.1 General [Replace the first paragraph with the following]

The Agency may change the Contract Documents or the scope of the Work, including additions and deletions of Work, by issuing a written Change Order to Contractor. Contractor shall expeditiously perform the revised Work pursuant to the Change Order. Contractor shall sign any Change Order that provides proper reduction of money and time, and/or proper additional money and time, based on the changes in the Work. If Contractor believes the Change Order should have smaller reductions in money or time, or larger increases in money or time, based on the changes in the Work, Contractor must follow the procedures in Section 2-10, below, including but not limited to Notice of Potential Change, Change Order Request, and Claim.

Unless a signed Change Order specifically states otherwise, it shall constitute full and final compensation, both money and time, for the specified issue, and shall act as a complete waiver by Contractor of all claims related to the specified issue.

2-8 EXTRA WORK

2-8.1 Markup [Add the following as the first paragraph]

The markups mentioned hereinafter shall include, but are not limited to, all costs for the services of superintendents, project managers, timekeepers, and other personnel not working directly on the change order and pickups or yard trucks used by the above personnel. These costs shall not be reported as labor or equipment elsewhere except when actually performing Work directly on the change order and then shall only be reported at the labor classification of the Work performed.

2-10 DISPUTED WORK [Delete second sentence and add the following]

Protest Procedures:

If the Contractor considers any Work demanded of him to be outside the requirements of the Contract, or if he considers any instruction, ruling, or decision of the inspector or Engineer to be unfair, he shall, within ten (10) working days after any such demand is made, or instruction, ruling, or decision is given, file a written protest with the Engineer, stating clearly and in detail his objections and reasons therefore, including an estimate of any additional money or time that Contractor believes should be granted by the City under the Contract.

Except for such protests and objections as are made of records, in the manner and within the time above stated, the Contractor shall be deemed to have waived and does hereby waive all claims for extra work, damages and extensions of time on account of demands, instructions, rulings and decisions of the Engineer.

Upon receipt of any such protest from the Contractor, the Engineer shall review the demands, instruction, ruling or decision objected to and shall promptly advise the Contractor, in writing, of his final decision.

Notice of Potential Change:

Contractor shall submit a written Notice of Potential Change for extra work, critical path delay, or additional money or time. Contractor shall submit written Notices of Potential Change to City within five (5) days of Contractor becoming aware of the issues creating the potential for change, unless the issues are, or may soon be, adversely affecting the costs or critical path of the Work, in which case the Contractor must submit the written notice without delay so the City may take immediate action to mitigate cost and schedule impacts of the change, if any. The written notice shall explain the nature of the potential change so the City may take action to mitigate costs and schedule impacts, if necessary.

When submitting a written Notice of Potential Change based on extra work, Contractor shall not perform the extra work until directed in writing to do so by City. When submitting a written Notice of Potential Change for an issue of critical path delay, Contractor shall proactively mitigate the effects of the alleged delay as much as reasonably possible so as to minimize any impact to the schedule, until otherwise directed by City. If Contractor intends to rely on City's acts or omissions in support of a request for a time extension, then Contractor must also provide the notice set forth in Section 2-6, above.

Failure to timely submit a written Notice of Potential Change shall constitute a complete waiver by Contractor of any right to later submit a change order request or pursue a Claim on that issue, or to later pursue any additional money or time extensions in any manner related to that issue, regardless of the merits. Contractor will not have satisfied a

condition precedent or exhausted administrative remedies. Contractor acknowledges that these written notices are of critical importance to the City's Work and Project management and the mitigation of Work and Project costs and delays.

Change Order Requests:

If, after submitting a written Notice of Potential Change, Contractor continues to believe that it is entitled to additional money or time (including but not limited to grant of a time extension; payment of money or damages arising from work done by, or on behalf of, the Contractor, payment of which is not otherwise expressly provided for or the claimant is not otherwise entitled to; or an amount the payment of which is disputed by the City) based on an issue, then Contractor shall submit a Change Order Request ("COR") to City within twenty (20) days of (i) becoming aware of the issues creating a potential change, or (ii) the date by which it should have become aware of the issues creating a potential change. A rejection at any time or a lack of a rejection by City of a Notice of Potential Change does not affect the timeline for submitting a COR.

Failure to timely submit a COR related to an issue, or failure to comply with any of the COR requirements in the Contract shall constitute a complete waiver by Contractor of any right to later submit a COR or Claim on that issue, or to later pursue any additional money (including time extensions) in any manner related to that issue, regardless of the merits. Contractor will not have satisfied a condition precedent or exhausted administrative remedies.

The COR shall state the grounds for the additional money or time requested and the amount of money or time requested, and Contractor shall include all information supporting the COR.

Contractor shall certify the COR using the form set forth below for certification of a Claim, except that every reference to "Claim" shall be changed to "COR." If a COR is submitted without certification, a certification can still be submitted within the COR timelines set forth above. If the COR is not timely certified, Contractor will have completely waived its rights to any money or time for that issue, as Contractor will not have satisfied a condition precedent or exhausted administrative remedies.

The City may accept the entire COR, accept part of the COR and reject the remainder, reject the entire COR, or request additional information. If the City does not respond within thirty (30) days by accepting the entire COR, accepting part of the COR and rejecting the remainder, or requesting additional information, the entire COR shall be deemed rejected as of the thirtieth (30th) day. If the City requests additional information, then the Contractor shall submit the information within fifteen (15) days of the date of the request and the City shall have fifteen (15) days after the receipt of the additional information to accept or reject (in whole or in part) the COR. If the City fails to respond within fifteen (15) days after the submission of additional information, the entire COR shall be deemed rejected as of the fifteenth (15th) day.

Definition of Claim:

A "Claim" is a separate demand by the Contractor for (a) a time extension, including, without limitation, relief from damages or penalties for delay assessed by City, (b) payment of money or damages arising from work done by, or on behalf of, the Contractor, and payment of which is not otherwise expressly provided for or the claimant is not otherwise entitled to, or (c) an amount the payment of which is disputed by the City. A Claim includes any claim within the scope of Public Contract Code Sections 20104 et seq. Resubmittal in any manner of a COR which was previously rejected (see above) constitutes a Claim, whether the COR was rejected in whole or in part, and whether the COR was rejected expressly or deemed rejected by City inaction. A Claim includes any dispute Contractor may have with the City, including one which does not require a Notice of Potential Change or COR (see above), and includes an alleged breach of contract by the City. A Claim shall also constitute a claim for purposes of the California False Claims Act. In the event of a conflict between a Claims provision in Division 1 of the Specifications and these provisions, these provisions shall take precedence.

The Notice of Potential Change and COR procedures above are less formal procedures which precede the more formal Claim. A Notice of Potential Change does not constitute a Claim. A COR does not constitute a Claim; **except that** if insufficient time remains before the Claim deadline (see below) for Contractor to submit a COR and for City to process and reject the COR (see above), then either (1) Contractor may submit a COR which City shall treat as a Claim, but only if the COR complies with all requirements, or (2) a COR is not required so long as a Claim complying with this Section 3.5 is timely submitted.

A Claim does not include vouchers, invoices, progress payment applications, or other routine or authorized forms of requests for progress payments on the Contract; however, those documents remain "claims" for purposes of the California False Claims Act. A Claim does not include a Government Code Claim. ("Government Code Claim" means a claim under Government Code Sections 900 et seq. and 910 et seq.)

Time for Submitting Claim:

Contractor shall submit a Claim to the City on or before the earlier of (a) 15 days after Completion of the Work or (b) the Contractor's submission of its date of the Final Progress Payment Application. City's rejection, or lack of rejection, of a COR at any time does not affect the deadline for filing a Claim.

In addition, on or before submitting its request for a final progress payment based on 100% Completion of the Work, Contractor shall submit to City, in writing, a summary of all Claims for money or time extensions under or arising out of this Contract which were timely filed and which were fully compliant with the Contract's requirements for Claims. This Claim summary requirement shall not extend the time for submitting a Claim.

Failure to timely submit a Claim, failure to include a Claim in the above Claim summary, or failure to comply with any of the Claim requirements in the Contract, including but not limited to this Section 3.5, will act as a complete waiver of Contractor's rights to (a) recover money or time on the issues for which a Claim was required, (b) submit a Government Code Claim for the money or time (see below), and (c) initiate any action, proceeding or litigation for the money or time, regardless of the merits, as Contractor will not have satisfied a condition precedent or exhausted administrative remedies. City does not have an obligation to reject the Claim for a failure to comply with any of the Claim requirements in the Contract, including the lack of certification; and any failure by City to reject, or any delay in rejecting, a Claim on that basis does not waive the City's right to reject the Claim on that basis at a later time. In no event may the Contractor reserve its rights to assert a Claim for a time extension or additional money beyond the timelines set forth in this provision unless the City agrees in writing to allow the reservation.

Content of Claim:

Every Claim shall be in writing. All money or time extensions sought must be stated and itemized in the Claim at the time submitted. The responsibility to substantiate Claims shall rest with the Contractor.

In addition, the Contractor shall include a certification with each and every Claim at the time of submission, as follows:

I, _____ [*name of declarant*], declare the following:

_____ [*Contractor company name*] has contracted with _____ [*public entity name*] for the _____ [*name of Contract*] Contract. _____ [*Contractor company name*] authorized me to prepare the attached Claim for money and/or time extension for _____ [*public entity name*] regarding this Contract (dated _____, 20____, titled _____, and requesting \$ _____ and/or ____ additional days), and I prepared the attached Claim. I am the most knowledgeable person at _____ [*Contractor company name*] regarding this Claim.

The attached Claim complies with all laws applicable to submission of a Claim, including but not limited to California Penal Code Section 72, Government Code Sections 12650 et seq. (False Claims Act), and Business and Professions Code Sections 17200 et seq. (Unfair Business Practices Act). I am aware that submission or certification of false claims, or other claims that violate law or the Contract, may lead to fines, imprisonment, and/or other serious legal consequences for myself or _____ [*Contractor company name*].

The attached Claim does not breach the Contract, is not a false claim, does not violate any applicable law, satisfies all provisions of the Contract applicable to submission of the Claim, only contains truthful and accurate supporting data, and only requests money and/or time extensions that accurately reflect the adjustments to money and time for which I believe that [public entity name] is responsible under its Contract with _____ [*Contractor company name*].

While preparing this declaration and Claim, I consulted with others (including attorneys, consultants, or others who work for _____ [*Contractor company name*]) when necessary to ensure that the statements were true and correct.

Contractor understands and agrees that any Claim submitted without this certification does not meet the terms of the Contract Documents; that City, or City's representatives, may reject the Claim on that basis; and that unless Contractor properly and timely files the Claim with the certification, Contractor cannot further pursue the Claim in any forum and all rights to additional money or time for the issues covered by the Claim are waived due to a condition precedent not having been satisfied.

I declare under the penalty of perjury under the laws of the State of California that the foregoing is true and correct. Executed _____, 2____, at _____, California.

_____ [*Name of Declarant*]

Contractor's failure to timely submit a certification will constitute a complete waiver of Contractor's rights to (a) recover money or time on the issues for which a Claim was required, (b) submit a Government Code Claim (see below) for the money or time, and (c) initiate any action, proceeding or litigation for the money or time, as Contractor will not have satisfied a condition precedent or exhausted administrative remedies.

Claims for Additional Money:

Each Claim for additional money (including but not limited to those described above) must include all facts supporting the Claim, including but not limited to all supporting documentation plus a written analysis as to (a) why the claimed cost was incurred, (b) why Contractor could not mitigate its costs, (c) why the claimed cost is the responsibility of the City, and (d) why the claimed cost is a reasonable amount. In no event will the Contractor be allowed to reserve its rights to assert a Claim for money at a later time, unless the City expressly agrees in writing to allow the reservation. Any costs, direct or indirect, not asserted shall be waived. A Claim may not include any costs incurred in preparation of the Claim or in preparation of any underlying COR, including but not limited to costs of delay analysis.

Claims for Additional Time:

If the Contractor wishes to make a Claim for an increase in the Contract Time pursuant to these provisions, the Claim shall include, but not be limited to, all facts supporting the Claim, all documentation of such facts, all information required by the Contract Documents, and a current schedule and delay analysis explaining (a) the nature of the delay, (b) the City's responsibility for the claimed delay, (c) the claimed delay's impact on the critical path, (d) the claimed delay's impact on the date of Completion (including an analysis of any float still remaining and whether the alleged delay in work exceeds such remaining float), and (e) why Contractor could not mitigate the delay impacts.

In the case of a continuing delay, only one (1) initial Claim is necessary that is based on estimates of when the continuing delay will end, but within twenty (20) days of the end of the continuing delay an updated final Claim must be submitted, which shall also be certified. In no event will the Contractor be allowed to reserve its rights to assert a Claim for a time extension, unless the City expressly agrees in writing to allow the reservation. Any time extension not asserted shall be waived.

If weather is the basis for a Claim for additional time, Contractor must provide City data and facts showing that the weather conditions were not foreseeable at the time of the bid, could not have been reasonably anticipated or mitigated during the Work, and had an adverse effect on the critical path of the scheduled construction.

"Pass-Through" Claims:

A Subcontractor or supplier to Contractor may not submit a request for additional time or money directly to the City. If a subcontractor or supplier submits a request for additional money or time to Contractor and Contractor wishes to pass it through to City, then Contractor must comply with all requirements of these provisions for Notices of Potential Change, Change Order Requests, and Claims. Contractor must prepare and submit its own analysis of the Subcontractor's request, and the Claim must include a copy of the Subcontractor's request along with any other necessary supporting documentation.

The Contractor's analysis of the Subcontractor's request must include Contractor's detailed explanation as to why the Subcontractor or supplier's request is the City's responsibility, including Contractor's analysis of (a) why the amount of damages the Subcontractor or supplier requests is justified and appropriate, (b) how Contractor's breach of the subcontract caused the Subcontractor or supplier to incur these damages, and (c) how the City's breach of the Contract caused the Contractor's breach of the subcontract. Any Contractor Claim that fails to include the above information, or that states that City is responsible for the Subcontractor's request only in the event that Contractor is found to owe money to Subcontractor, shall act as a complete waiver of Contractor's rights to (a) recover money or time on the issues for which a Claim was required, (b) submit a Government Code Claim (see below) for the money or time, and (c) initiate any action, proceeding or litigation for the money or time. Contractor will not have satisfied a condition precedent or exhausted administrative remedies.

Procedures for Claims of \$375,000 or Less:

Pursuant to Public Contract Code Section 20104.2, Claims less than or equal to \$375,000 are subject to the following requirements.

Claims Less Than \$50,000

For Claims of less than fifty thousand dollars (\$50,000), the City shall respond in writing to any written Claim within 45 days of receipt of the Claim, or may request, in writing, within 30 days of receipt of the Claim, any additional documentation supporting the Claim or relating to defenses to the Claim the City may have against the Contractor.

If additional information is thereafter required, it shall be requested and provided pursuant to this subsection, upon mutual agreement of the City and Contractor. If City and Contractor cannot reach mutual agreement, Contractor's failure to provide any reasonably-requested information within fifteen (15) days after the request, shall act as a complete waiver of Contractor's rights to (a) recover money or time on the issues for which a Claim was required, (b) submit a Government Code Claim (see below) for the money or time, and (c) initiate any action, proceeding or litigation for such money or time. Contractor will not have satisfied a condition precedent or exhausted administrative remedies.

The City's written response to the Claim, as further documented, shall be submitted to the Contractor within fifteen (15) days after receipt of the further documentation, or within a period of time no greater than that taken by the Contractor in producing the additional information, whichever is greater.

Claims Over \$50,000, But Not Over \$375,000

For claims over fifty thousand dollars (\$50,000) and less than or equal to three hundred seventy-five thousand dollars (\$375,000), the City shall respond in writing to all written Claims within sixty (60) days of receipt of the Claim, or may request, in writing, within thirty (30) days of receipt of the Claim, any additional documentation supporting the Claim or relating to defenses to the Claim the City may have against the Contractor.

If additional information is thereafter required, it shall be requested and provided pursuant to this subsection, upon mutual agreement of the City and Contractor. If City and Contractor cannot reach mutual agreement, Contractor's failure to provide any reasonably-requested information within thirty (30) days after the request shall act as a complete waiver of Contractor's rights to (a) recover money or time on the issues for which a Claim was required, (b) submit a Government Code Claim (see section below) for such money or time, and (c) initiate any action, proceeding or litigation for such money or time. Contractor will not have satisfied a condition precedent or exhausted administrative remedies.

The City's written response to the Claim, as further documented, shall be submitted to the Contractor within thirty (30) days after receipt of the further documentation, or within a period of time no greater than that taken by the Contractor in producing the additional information or requested documentation, whichever is greater.

Meet and Confer

If the Contractor disputes the City's written response, or the City fails to respond within the time prescribed, the Contractor may so notify the City, in writing, either within fifteen (15) days of receipt of the City's response or within fifteen (15) days of the City's failure to respond within the time prescribed, respectively, and demand an informal conference to meet and confer for settlement of the issues in dispute. Upon a demand, the City shall schedule a meet and confer conference for settlement of the dispute, which shall take place within thirty (30) days of the demand. Upon written agreement of the City and Contractor, the conference may take place during regularly scheduled Project meetings.

If Contractor fails to timely notify the City that it wishes to meet and confer pursuant to the previous paragraph, then Contractor will have waived all rights to (a) recover money or time on the issues for which a Claim was required, (b) submit a Government Code Claim (see below) for such money or time, and (c) initiate any action, proceeding or litigation for such money or time. Contractor will not have satisfied a condition precedent or exhausted administrative remedies.

Government Code Claim

If the Claim or any portion remains in dispute after the meet and confer conference and Contractor wishes to pursue it, the Contractor **must** file a timely and proper Government Code Claim. The filing of a Government Code Claim is specifically required in addition to all contractual procedures above. The above contractual procedures do not act as a substitute for the Government Code Claim process, and the two sets of procedures shall be sequential with the contractual procedures coming first.

Failure to timely file a Government Code Claim shall act as complete waiver of Contractor's rights to (a) recover money or time on the issues for which a Government Code Claim was required, and (b) initiate any action, proceeding or litigation for such money or time. Contractor will not have satisfied a condition precedent or exhausted administrative remedies.

City and Contractor shall proceed with the Government Code Claim according to Government Code Section 900 et seq., and as otherwise permitted by law. For purposes of the applicable Government Code provisions, and as provided in Public Contract Code Section 20104.2(e), the running of the time period within which a Contractor must file a Government Code Claim shall be tolled from the time the Contractor submits a written Claim under the above provisions until the time that the Claim is denied, in whole or in part, as a result of the meet and confer process described above, including any period of time utilized by the meet and confer process.

Procedures for Claims over \$375,000:

Contractor and City shall proceed with Claims over \$375,000 pursuant to the above provisions for Claims of \$375,000 or less, **except as follows:** (a) the provisions regarding Claims under \$50,000 shall not apply; (b) the City shall respond in writing to all written Claims within 90 days of receipt of the Claim, or may request, in writing, within 45 days of receipt of the Claim, any additional documentation supporting the Claim or relating to defenses to the Claim the City may have against the Contractor; and (c) City shall respond within 45 days after receipt of the further documentation, or within a period of time no greater than that taken by the Contractor in producing the additional information or documentation, whichever is greater.

Mediation:

After the meet and confer process, the parties may agree to mediate, or use any other dispute resolution process, regarding any issues remaining in dispute. However, the mediation or dispute resolution process shall not affect the requirements and deadlines under law or this Contract, including submission of a Government Code Claim and filing a complaint.

Continuing Contract Performance:

Despite submission or rejection of a Notice of Potential Change, COR or Claim, the Contractor shall proceed diligently with performance of the Contract as directed by City, and the City shall continue to make any undisputed payments in accordance with the Contract.

Trenching More than Four Feet:

When any excavation or trenching extends greater than four feet (4') below the surface, the Contractor shall promptly, and before the following conditions are disturbed, notify the public entity, in writing, of any (1) material that the Contractor believes may be material that is hazardous waste, as defined in Section 25117 of the Health and Safety Code, that is required to be removed to a Class I, Class II, or Class III disposal site in accordance with the provisions of existing law; (2) subsurface or latent physical conditions at the site differing from those indicated by information about the site made available to bidders prior to the deadline for submitting bids; and (3) unknown physical conditions at the site of any unusual nature, different materially from those ordinarily encountered and generally recognized as inherent in work of the character provided for in the Contract.

The public entity shall promptly investigate the conditions, and if it finds that the conditions do materially so differ, or do involve hazardous waste, and cause a decrease or increase in the Contractor's cost of, or the time required for, performance of any part of the Work shall issue a change order under the procedures described in the Contract.

In the event that a dispute arises between the public entity and the Contractor whether the conditions materially differ, or involve hazardous waste, or cause a decrease or increase in the Contractor's cost of, or time required for, performance of any part of the Work, the Contractor shall not be excused from any deadline for Completion provided for by the Contract, but shall proceed with all Work to be performed under the Contract. The Contractor shall retain any and all rights provided either by Contract or by law which pertain to the resolution of disputes and protests between the contracting parties.

SECTION 3 CONTROL OF WORK

3-5 INSPECTION [Add the following]

The Agency's supervision and inspection of the Work does not act as acceptance or agreement with any defective aspect of that Work, nor as a waiver of the Agency's claims against the Contractor regarding that Work. Responsibility for the quality of the Work is the Contractor's.

3-7 CONTRACT DOCUMENTS

3-7.1 General [Replace the first paragraph with the following]

The Contractor shall maintain a control set of Plans and Specifications on the project site at all times. All final locations determined in the field, and any deviations from the Plans and Specifications, shall be marked in red on this control set to show the as-built conditions. Upon Completion of all Work, the Contractor shall return the control set to the Engineer. Final payment will not be made until this requirement is met.

3-7.2 Precedence of the Contract Documents [Replace with the following]

In the case of conflict between any of the Contract Documents, the order of precedence in Standard Specification Section 2-5.2(a)-(j) is amended as follows:

- (a) Permits issued by jurisdictional regulatory agencies.
- (b) Change Orders and Supplemental Agreements, whichever occurs last.
- (c) Contract/Agreement.
- (d) Addenda.
- (e) Contractor's Proposal (including Bid Sheet, subcontractor list, non-collusion declaration, bid bond, Iran Contracting Act Declaration, and Sufficient Funds Declaration).
- (f) Performance and Payment Bonds.
- (g) Notice Inviting Bids.
- (h) Instructions to Bidders.
- (i) Special Provisions.
- (j) General Provisions.
- (k) Project Plans.
- (l) Standard Plans.
- (m) General Specifications.
- (n) Standard Specifications (Greenbook).
- (o) Reference Specifications.
- (p) Workers Compensation Certification.

For any conflict in the Contract Documents not resolved by the above order of precedence, the more stringent, higher quality, and/or greater quantity of Work shall control. Detailed drawings shall take precedence over general drawings.

3-12 WORK SITE MAINTENANCE

3-12.4.2 Storage in Public Streets [Replace with the following]

No storage of equipment or materials shall be allowed within the public right-of-way outside of working hours.

The Contractor may, at his own expense, maintain and operate a work and storage area outside of the public right-of-way. In such case, the Contractor shall submit to Agency written authorization from the owners of the subject property prior to occupation. Occupation of site without written authorization shall be grounds for immediate suspension of work. Location of the site is to be approved by Agency. Condition and operation of yard shall conform to these Specifications. The Contractor shall assume full responsibility for all damage to the site resulting from his operations and shall repair and/or replace same, at his own expense, to the satisfaction of the owner of the subject property. The Contractor shall vacate site and return it to pre-project condition within five (5) working days following application for Notice of Completion. The Contractor shall obtain a written release from the property owner accepting the condition of the vacated site and releasing the Contractor from any further clean-up or restoration work and shall submit a copy of such release to Agency. The Notice of Completion will not be issued until said release is submitted.

3-13 COMPLETION, ACCEPTANCE, AND WARRANTY

3-13.3 Warranty [add the following]

Nothing contained in this Section 6-8.3 shall be construed to establish a period of limitation with respect to other obligations which the Contractor might have under the Contract Documents. Establishment of the time period of one (1) year relates only to the specific warranty obligation of the Contractor to correct the Work after the date of commencement of warranties, and has, for example, no relationship to the time within which the obligation to comply with the Contract Documents may be sought to be enforced by Agency, or to the time within which proceedings may

be commenced by Agency to establish the Contractor's liability with respect to the Contractor's obligations other than specifically to correct the Work.

SECTION 4 CONTROL OF MATERIALS

4-1 GENERAL [Add the following to the first paragraph]

Warranties or guarantees on accepted Work will be for one year following project acceptance.

4-3 INSPECTION

4-3.2 Inspection by the Agency. [Add the following]

The Agency will pay for inspection and materials testing. The Contractor shall pay for retests and re-inspections due to failure to meet specifications.

Testing Laboratory Services Furnished by the City:

The City shall pay all charges of testing laboratories for quality control tests made in the field or laboratory on concrete, asphalt mixtures, moisture-density (Proctor) and relative density tests on embedment, fill, and backfill materials, in-place field density tests on embedments and fills, and other materials and equipment, during and after their incorporation in the Work. Field sampling and testing will be performed by Engineer personnel, in the general manner indicated in the specifications, with minimum interference with construction operations. Engineer shall determine the exact time and location of field sampling and testing, and may require such additional sampling and testing as necessary to determine that materials and equipment conform with data previously furnished by Contractor and with the Contract Documents.

Arrangements for delivery of samples and test specimens to the testing laboratory will be made by the City. The testing laboratory shall perform all laboratory tests within a reasonable time.

Contractor shall furnish all sample materials and cooperate in the sampling and field testing activities, interrupting the Work when necessary. When sampling or testing activities are performed in the field by Engineer, Contractor shall furnish personnel and facilities to assist in the activities as required.

Transmittal of Test Reports:

Written reports of tests and engineering data furnished by Contractor for Engineer's review of materials and equipment proposed to be used in the Work shall be submitted as specified for Shop Drawings.

The testing laboratory retained by the Engineer will furnish three copies of a written report of each test performed by laboratory personnel. Two copies of each test report will be transmitted to the Engineer and one copy to the Contractor within three (3) working days after each test is completed.

SECTION 5 LEGAL RELATIONS AND RESPONSIBILITIES

5-3 LABOR

5-3.1 General [Add the following]

The Contractor, and all subcontractors, suppliers, and vendors shall comply with applicable Agency, State, and Federal orders regarding affirmative action to ensure equal employment opportunities and fair employment practices. Failure to file any report due under said orders will result in suspension of periodic progress payments. The Contractor shall ensure unlimited access to the Job site for all equal employment opportunity compliance officers.

This Contract is subject to compliance registration, monitoring and enforcement by the Department of Industrial Relations (DIR) and all related requirements of Senate Bill 854 (Labor Code Sections 1715.5, 1725.5, 1771.1, 1771.1a and 1771.4.)

Contractor is responsible for employing apprentices as required by Section 1777.5 of the Labor Code and all other law.

Pursuant to Section 6109(a) of the Public Contract Code, Contractor may not perform the Work with a subcontractor that is ineligible pursuant to Labor Code Sections 1777.1 or 1777.7.

A contractor or subcontractor shall not be qualified to submit a bid or to be listed in a bid proposal subject to the requirements of Public Contract Code Section 4104, nor shall it be qualified to enter into, or engage in the performance of, any contract of public work, unless it is currently registered and qualified under Labor Code Section 1725.5 to perform public work (as "public work" is defined by Division 2, Part 7, Chapter 1 (Sections 1720 et seq.) of the Labor Code).

5-3.2 Prevailing Wages [Add the following]

Pursuant to Section 1773.2 of the Labor Code, the current prevailing rate of per diem wages at the time of the Bid as determined by the Director of the Department of Industrial Relations (DIR) are on file at the office of the Engineer. The Contractor shall post a copy of these rates at the Work site. Pursuant to Section 1771 and 1774 of the Labor Code, the Contractor and any Subcontractors shall pay not less than the specified prevailing rates of wages to workers employed on the Contract. If the Contract is Federally-funded, the Contractor and any Subcontractors shall not pay less than the higher of these rates or the rates determined by the United States Department of Labor. Pursuant to Section 1775 of the Labor Code, the Contractor and any Subcontractors, shall, as a penalty to the Agency, forfeit the prescribed amounts per calendar day, or portion thereof, for each worker paid less than the prevailing wage rates.

5-3.3 Payroll Records [Replace sentence with the following]

Pursuant to Section 1776 of the Labor Code, the Contractor shall keep, make available, and submit to the Engineer certified payroll records. Payroll records shall be submitted to the Engineer at least once each month. Progress payments will be withheld pending receipt of any outstanding reports.

5-4 INSURANCE [See Instructions to Bidders]

5-4.1 General [Add the following paragraphs]

The Contractor shall defend, indemnify and save harmless the City of Mission Viejo, the State of California, the County of Orange, or any incorporated city from all claims or suits for damages arising from his prosecution of the Contract Work. The Agency shall give timely notification to Contractor of the receipt of any third-party claim relating to the contract.

All liability insurance policies shall bear an endorsement or shall have attached a rider whereby it is provided that, in the event of expiration or proposed cancellation of such policies for any reason whatsoever, the Agency shall be notified by registered mail, return receipt requested, giving a sufficient time before the date thereof to comply with any applicable law or statute, but in no event less than thirty (30) days before expiration or cancellation is effective. The following statement shall be included on all insurance policies:

Additional Insured: The insurer agrees that the City of Mission Viejo and its City Council and/or all City Council-appointed groups, committees, boards, and any other City Council-appointed body and/or elective and appointive officers, servants, or employees of the City, when acting as such, are additional insured hereunder for the acts of the insured and such insurance shall be primary to any insurance of the City.

The Contractor agrees to protect, defend, and indemnify the City of Mission Viejo against loss, liability, damage, or expense by reason of any suit claims, demands, judgments and causes of action caused by the Contractor, his employees, agents, or any subcontractor, or by any third party arising out of or in consequence of the performance of all or any operations covered by Contractor's policies. The Contractor, at his option, may include such coverage under his Public Liability coverage.

5-4.2 General Liability Insurance [add the following]

The City of Mission Viejo, the City Council, and the Engineer shall not be answerable or accountable in any manner for any loss or damage that may happen to the Work or any part thereof; or for any of the materials or other things used or employed in performing the Work; or for injury to any person or persons, either workmen or the public or for damage to any person or persons either workmen or the public; or for damage to adjoining property from any cause which might have been prevented by the Contractor, or his workmen, or anyone employed by him; against all of which injuries or damages to persons and property the Contractor, having control over such work, must properly guard.

The Contractor shall be responsible for any damage to any person or property resulting from defects and/or obstructions at any time before Completion and final acceptance of the Work and shall indemnify and save harmless the City of Mission Viejo, the City Council, and the Engineer from all suits or actions of every name and description brought for, or

on account of, any injuries or damages received or sustained by any person or persons, by the Contractor, his servants or agents, in the construction of the Work or in consequence of any negligence in guarding the same, in improper materials used in its construction, by or on account of any act or omission of the Contractor or his agents, and so much of the money due the Contractor under and by virtue of the Contract as shall be considered necessary by the City may be retained by the City until disposition has been made of such suits or claims for damages aforesaid.

If, in the opinion of the Engineer, the precautions taken by the Contractor are not safe or adequate at any time during the life of the Contract, the Engineer may order the Contractor to take further precautions; and if the Contractor shall fail to do so, the Engineer may order the Work done by others and charge the Contractor for the cost thereof, and such cost to be deducted from any moneys due or becoming due the Contractor. Failure of the Engineer to order such additional precautions, however, shall not relieve the Contractor from his full responsibility for public safety or its obligations under the Contract.

From time to time, during the period of this Contract, the City may be served with claims, as a result of conduct by Contractor, which claims are for property damage or other damage in amounts of \$500.00 or less. These claims may be resolved informally by City, within City's discretion, and charged back against Contractor by funds held in retention, or for progress payments, to meet these claims. The City will appoint a Claims Administrator who will act on behalf of the City and Contractor. The Administrator will recommend to City the resolution of any claim. The Claims Administrator's recommendation for payment shall be paid by Contractor within thirty (30) days of the date of the recommendation. If Contractor fails to make payment to claimant within thirty (30) days of the Administrator's decision, the City may make payment to the claimant and withhold, as retention, sufficient funds to reimburse City upon Completion of the Contract. Prior to making his recommendation, the Administrator will obtain from Contractor all evidence relevant to the claim. Contractor will have ten (10) days from the date requested by the Administrator to submit any evidence in the defense of the claim. Failure to do so waives any objection by Contractor to payment of the claim if, after an independent investigation, it is the opinion of the Administrator to make payment of that claim.

5-7 SAFETY

5-7.1 Work Site Safety [Add the following paragraph]

The Contractor shall comply with the provisions of any Agency ordinances or regulations regarding requirements for the protection of excavations and the nature of such protection.

SECTION 6 PROSECUTION, PROGRESS, AND ACCEPTANCE OF THE WORK

6-1 CONSTRUCTION SCHEDULE AND COMMENCEMENT OF THE WORK

6-1.1 Construction Schedule [Add the following]

The Contractor's proposed baseline construction schedule shall be submitted to the City within ten (10) working days after the date of the Notice of Award of Contract. The schedule shall be supported by written statements from each supplier of materials or equipment indicating that all orders have been placed and acknowledged and setting forth the dates that each item will be delivered.

6-1.2 Commencement of the Work [Add the following]

Prior to issuing the Notice to Proceed, the City will schedule a pre-construction meeting with the Contractor to review the proposed construction schedule and delivery dates, arrange the utility coordination, discuss construction methods, and clarify inspection procedures.

The Contractor shall submit periodic progress reports to the City by the tenth (10th) day of each month. The report shall include an updated construction schedule showing as-built schedule for Completed Work and as-planned schedule for remaining Work. Any deviations from the original schedule shall be explained. Progress payments will be withheld pending receipt of any outstanding reports.

6-3 TIME OF COMPLETION

6-3.1 General [Add the following]

The time for Completion shall be as set forth in the General Specifications.

6-4 DELAYS AND EXTENSIONS OF TIME

6-4.1 General [Add the following to the end of this section]

No time extension shall be granted unless the claimed delay meets each and every of the following conditions:

- (a) The delay was caused by unforeseen events and was beyond the control of Contractor and its subcontractors and material suppliers;
- (b) The delay was caused by events of which Contractor was not advised at or before the time of bidding;
- (c) The delay impacted and delayed (i) the controlling items of Work (i.e., the as-built critical path, as determined from the as-planned schedule and the actual progress of the Work), or (ii) the Completion of the whole Work within the Contract time;
- (d) The delay was not caused by Contractor or its subcontractors or suppliers, including but not limited to their breaches of contract or the standard of care;
- (e) The delay was not associated with loss of time resulting from the necessity of submittals to Agency for approval, or from necessary Agency surveys, measurements, inspections and testing;
- (f) The delay was not caused by usual or common weather for the time of year, including usual or common severe weather; and
- (g) The delay could not have been prevented by the exercise of care, prudence, foresight, and diligence by Contractor.

Excusable delays may include acts of God, acts of public enemy, acts of the Owner or anyone employed by it, acts of another contractor in performance of a contract (other than this Contract) with the Agency, fires, floods, epidemics, quarantine restrictions, labor disputes, unusually and uncommonly severe weather for the time of year, unforeseen site conditions, or delays of subcontractors due to such causes. Agency shall take into consideration other relevant factors such as concurrent delays.

Contractor has the burden of proving that any delay was excusable, including but not limited to an analysis that establishes no concurrency.

No extension of time will be granted for an excusable delay caused by a shortage of materials unless the Contractor furnishes to the Engineer documentary proof that the Contractor has made every effort to obtain the materials from all known sources within reasonable reach of the Work in a diligent and timely manner, and further proof in the form of supplementary progress schedules that the inability to obtain the materials when originally planned did in fact cause a delay in final Completion of the entire Work which could not be compensated for by revising the sequence of the Contractor's operations. The term "shortage of materials" shall apply only to materials, articles, parts or equipment which are standard items and are to be incorporated in the Work. The term "shortage of materials" shall not apply to materials, parts, articles or equipment which are processed, made, constructed, fabricated or manufactured to meet the specific requirements of the contract. Only the physical shortage of material will be considered under these provisions as a cause for extension of time. Delays in obtaining materials due to priority in filling orders will not constitute a shortage of materials.

6-4.3 Payment for Delays [Replace paragraph with the following]

To be compensable, an excusable delay must be one for which the Agency is responsible, where the delay was unreasonable under the circumstances involved, and where the delay was not within the contemplation of the parties; **however**, Contractor shall not be entitled to monetary compensation when (a) Contractor could have reasonably anticipated the delay and avoided or minimized the cost impacts of it, such as judicious handling of forces, equipment, or plant, (b) there was a concurrent delay which does not qualify for monetary compensation under this paragraph, (c) the cause of the delay was reasonably unforeseen by the Agency or the delay was caused by factors beyond the control of the Agency, including but not limited to a delay under Section 2.2.8 above or a delay caused by a utility company's failure to perform despite Agency's reasonable arrangements for such performance; or (d) any other defense available to Agency under law or equity applies. Contractor has the burden of proving that any delay was excusable and compensable, including an analysis that establishes non-concurrency.

The Contractor may not seek damages for delay of a planned Completion of the Work before the contractual deadline for Completion of the Work.

6-8 TERMINATION OF THE CONTRACT FOR CONVENIENCE

[Replace the first sentence with the following]

The Board may terminate the Contract for any reason at any time.

[Replace the last two sentences with the following]

If the Contractor disagrees with the amount determined by the Agency, the Contractor shall follow all procedures of Section 2-10, above.

6-9 LIQUIDATED DAMAGES [Replace last sentence of first paragraph with the following]

For each calendar day the Work is not Complete in excess of the time specified in the Contract for Completion of the Work, as adjusted in accordance with Subsection 6-4, the Contractor shall pay to the Agency, or have withheld from moneys due it, the sum of **Twenty-Five Hundred Dollars (\$2,500.00)**.

[Replace first sentence of the last paragraph with the following]

Execution of the Contract shall constitute agreement by the Agency and Contractor that **Twenty-Five Hundred Dollars (\$2,500.00)** per day is the minimum value of the costs and actual damage caused by the failure of the Contractor to Complete the Work within the allotted time.

SECTION 7 MEASUREMENT AND PAYMENT

7-3 PAYMENT

7-3.1 General [Replace last paragraph with the following]

Agency shall release retention to Contractor pursuant to Public Contract Code Section 7107, which requires, among other things, that retention be released within sixty (60) days after Completion of the Work.

The Agency may withhold from a progress payment or release of retention, in whole or in part, to such extent as may be necessary to protect the Agency due to any of the following.

- A. Defective or incomplete Work not remedied;
- B. Stop Payment Notices. For any stop payment notice given to the Agency, the Agency shall withhold the amount stated in the stop payment notice, the stop notice claimant's anticipated interest and court costs and an amount to provide for the public entity's reasonable cost of any litigation pursuant to the stop payment notice. For any stop payment notice action the parties resolve before judgment is entered, Agency has the right to permanently withhold for any reasonable cost of litigation for that stop payment notice, even if it exceeds the amount originally withheld by Agency for the estimated reasonable cost of litigation. However, if (1) the Contractor at its sole expense provides a bond or other security satisfactory to the Agency in the amount of at least one hundred twenty-five percent (125%) of the claim, in a form satisfactory to the Agency, which protects the Agency against such claim, and (2) the Agency chooses to accept the bond, then Agency would release the stop payment notice funds withheld to the Contractor, except that Agency may permanently withhold for any reasonable cost of litigation. Any stop payment notice release bond shall be executed by a California-admitted, fiscally solvent surety, completely unaffiliated with and separate from the surety on the payment and performance bonds, that does not have any assets pooled with the payment and performance bond sureties;
- C. Liquidated damages against the Contractor, whether already accrued or estimated to accrue in the future;
- D. Reasonable doubt that the Work can be Completed for the unpaid balance of any Contract Sum or by the Completion deadline;
- E. Damage to the property or work of the Agency, another contractor, or subcontractor;

- F. Unsatisfactory prosecution of the Work by the Contractor;
- G. Failure to store and properly secure materials;
- H. Failure of the Contractor to submit on a timely basis, proper and sufficient documentation required by the Contract Documents, including, without limitation, monthly progress schedules, shop drawings, submittal schedules, schedule of values, product data and samples, proposed product lists, executed change orders, and verified reports;
- I. Failure of the Contractor to maintain as-built or record drawings;
- J. Erroneous estimates by the Contractor of the value of the Work performed, or other false statements in an Application for Payment;
- K. Unauthorized deviations from the Contract Documents;
- L. Failure of the Contractor to prosecute the Work in a timely manner in compliance with established progress schedules and Completion deadlines;
- M. Subsequently discovered evidence or observations nullifying the whole or part of a previously issued Certificate for Payment;
- N. Failure by Contractor to pay subcontractors or material suppliers as required by Contract or law, which includes but is not limited to Contractor's failure to pay prevailing wage and any assessment of statutory penalties;
- O. Overpayment to Contractor on a previous payment;
- P. Credits owed to Agency for reduced scope of Work or Work that Contractor will not perform;
- Q. The estimated cost of the Agency's performance of corrective Work;
- R. Actual damages related to false claims by Contractor;
- S. Breach of any provision of the Contract Documents;
- T. Agency's potential or actual loss, liability, or damages caused by the Contractor; and
- U. As permitted by other provisions in the Contract or as otherwise allowed by law, including statutory penalties Agency or other entities assessed against Contractor. [See e.g., Labor Code Section 1813 (working hours) or Public Contract Code Section 4110 (subcontractor listings and substitutions).]

Agency may, but is not required to, provide to Contractor with the progress payment written notice of the items for which Agency is withholding amounts from the payment. To claim wrongful withholding by the Agency, or if Contractor otherwise disputes any amount being withheld, Contractor must submit an inquiry in writing to Agency within thirty (30) days of receipt of the notice, and Agency shall respond within fifteen (15) days of receipt of the inquiry. If any disputed issues remain unresolved after Agency's response, Contractor shall timely submit a Claim pursuant to Section 3-5, above.

For any withhold amount based on an estimate where the actual amount will later become known and certain, the Owner may withhold 125% of the estimate. After the actual amount becomes known, if that actual amount exceeds the amount previously withheld, Agency may withhold additional amounts from Contractor to cover the excess amount; and if available funds are not sufficient, Contractor shall pay Agency the difference. After the actual amount becomes known and certain, if that amount is less than the amount previously withheld, the Agency will pay and release any amount withheld over that certain and known amount.

When Contractor removes or cures the grounds for withholding amounts, payment shall be made for amounts withheld because of them. No interest shall be paid on any retainage or amounts properly withheld by the Agency.

Neither Agency's overpayment to Contractor, nor Agency's failure to withhold an amount from payment that Agency had the right to withhold, shall constitute a waiver by Agency of its rights to withhold those amounts from future payments to Contractor or to otherwise pursue recovery of those amounts from Contractor.

Pursuant to and in accordance with the provisions of Government Code Section 8546.7, or any amendments thereto, all books, records, and files of the Agency, the Contractor, or any Subcontractor connected with the performance of this Contract involving the expenditure of State funds in excess of Ten Thousand Dollars (\$10,000.00), including, but not limited to, the administration thereof, shall be subject to the examination and audit of the Office of the Auditor General of the State of California for a period of three (3) years after release of all retention under this Contract. Contractor shall preserve and cause to be preserved such books, records, and files for the audit period. During the progress of the Work and for three (3) years after release of all retention under the Contract, Agency shall also have the right to an audit, and Contractor must cooperate by producing all information requested within seven (7) days.

7-3.2 Partial and Final Payment [Replace the last paragraph with the following]

The final progress payment will not be released until the Contractor returns the control set of Plans and Specifications showing the as-built conditions.

In conformance with the State of California Government Code, Chapter 13, Section 4590, the Contractor may substitute securities for any moneys withheld by the Agency to secure performance under the contract.

Within thirty (30) days after receipt of an undisputed and properly submitted Application for Payment, Contractor shall be paid by Agency.

7-3.3 Delivered Materials [Replace with the following]

Materials and equipment delivered but not incorporated into the Work will not be included in the estimate for progress payment, unless specifically approved by the agency.

7-4.3 Markup

7-4-3.1 Work by the Contractor [Add the following as the first paragraph]

The markups mentioned hereinafter shall include, but are not limited to, all costs for the services of superintendents, project managers, timekeepers, and other personnel not working directly on the change order and pickups or yard trucks used by the above personnel. These costs shall not be reported as labor or equipment elsewhere except when actually performing Work directly on the change order and then shall only be reported at the labor classification of the Work performed.

SECTION 8 AUDIBLE PEDESTRIAN PUSH BUTTON ASSEMBLY

8.1 GENERAL

General

Furnish and install **Polara Audible Pedestrian Push Button–Model iN2-5 BB 1 B or approved equal** at all pedestrian crosswalk for the following intersections:

1. Alicia Parkway at Olympiad Plaza	4 audible pedestrian push buttons, 1 CCU
2. Alicia Parkway at Calle Azorin	8 audible pedestrian push buttons, 1 CCU
3. Alicia Parkway at Cypress	8 audible pedestrian push buttons, 1 CCU
4. Alicia Parkway at Via Aurora	8 audible pedestrian push buttons, 1 CCU
5. Alicia Parkway at Via Burgos	4 audible pedestrian push buttons, 1 CCU
6. Alicia Parkway at Coronel	8 audible pedestrian push buttons, 1 CCU
7. Alicia Parkway at Via Linda	4 audible pedestrian push buttons, 1 CCU
8. Alicia Parkway at Via Fabricante	4 audible pedestrian push buttons, 1 CCU
9. Jeronimo Road at Montilla	8 audible pedestrian push buttons, 1 CCU
10. Jeronimo Road at Cordillera	8 audible pedestrian push buttons, 1 CCU
11. Jeronimo Road at Acero	6 audible pedestrian push buttons, 1 CCU
12. La Paz Road at Commerce Center	8 audible pedestrian push buttons, 1 CCU
13. La Paz Road at Ralph's Driveway	8 audible pedestrian push buttons, 1 CCU
14. La Paz Road at Spadra	4 audible pedestrian push buttons, 1 CCU
15. La Paz Road at Pradera Drive	4 audible pedestrian push buttons, 1 CCU
16. Chrisanta Drive at Pradera Drive	8 audible pedestrian push buttons, 1 CCU
17. La Paz Road at Mosquero	6 audible pedestrian push buttons, 1 CCU
18. La Paz Road at Chrisanta Drive	8 audible pedestrian push buttons, 1 CCU
19. Crown Valley Parkway at Bellogente	8 audible pedestrian push buttons, 1 CCU
20. Crown Valley Parkway at Kaleidoscope	6 audible pedestrian push buttons, 1 CCU
21. Medical Center at Hospital	6 audible pedestrian push buttons, 1 CCU
22. Muirlands Boulevard at Marathon	4 audible pedestrian push buttons, 1 CCU
23. Trabuco Road at Puerta De Luz	8 audible pedestrian push buttons, 1 CCU
24. Santa Margarita Parkway at Monterey	4 audible pedestrian push buttons, 1 CCU

Definitions

APS	As defined in the California MUTCD.
Accessible walk indication	Activated audible and vibrotactile action during the walk interval.
Ambient sound	Background sound level in dB at a given location.
Ambient sound sensing microphone	Microphone that measures the ambient sound level in dB and automatically adjusts the APS speaker's volume, accordingly.
APS pedestrian push button (APS PPB) assembly	Assembly that connects a pedestrian push button to an APS electronic device to actuate the components of the APS.
Audible speech walk message	Audible prerecorded message that communicates to pedestrians which street has the walk interval.

Programming mechanism	Device to program the APS operation.
Push button information message	Audible prerecorded message actuated when the push button is pressed and the walk interval is not timing.
Push button locator tone	As defined in the California MUTCD.
Vibrotactile pedestrian device	As defined in the California MUTCD.

Submittals

Submit the APS wiring diagram and product data.

Submit 3 APS user and operator manuals for each signalized location. Manuals must include a master item index that describes the purpose of each manual and brief description to the directory. The index must include an overall description of the APS and its associated equipment and cables with illustrative block diagrams, manufacturer contact information, technical data specification, parts list, part descriptions, and settings. The manuals must include fault diagnostic and repair procedures and procedures for preventative maintenance in order to maintain APS performance parameters.

Before shipping APSs to the job site, submit APSs and the following to the Transportation Laboratory:

1. Delivery form including contract number and contact information
2. List containing all APS serial numbers
3. Manufacturer's name, trademark, model number, lot number, and month and year of manufacture
4. Programming mechanism if not integral to the APS

Submit a record of completed field tests, APS final configuration, audible sound levels and threshold, and a list of all parameter settings.

Quality Control and Assurance

The APS must be compatible with the Econolite ASC/3 and Cobalt controller assembly.

Power to the APS must come through the standard pedestrian push button wires from the cabinet.

Functional Testing

Field tests must be completed twice, when traffic is noisy (e.g., peak traffic hours) and when traffic is quiet (e.g., off peak hours). Notify the Engineer fifteen (15) days before testing the APS.

Warranty

Provide a 2-year manufacturer replacement warranty for the APS effective from the date of installation against any defects or failures. All warranty documentation must be submitted to the Engineer before installation.

Replacement parts must be provided within ten (10) days after receipt of the failed part at no cost to the City and must be delivered to Mission Viejo City Hall, Department of Public Works, 200 Civic Center, Mission Viejo, California 92691, Phone No. 949-470-8422.

Materials

The APS PPB assembly must include:

1. PPB actuator with a minimum diameter of two inches (2"). The PPB must be rainproof and shockproof in any weather condition. If a mechanical switch is used, the switch must have:
 - a. Operating force of 3.5 lbs
 - b. Maximum pretravel of 5/64 inch
 - c. Minimum overtravel of 1/32 inch
 - d. Differential travel from 0.002 to 0.04 inches

2. Vibrotactile device on the push button or on the APS. The device may be a vibrotactile arrow or other vibrating surface approved by the Engineer.
3. Enclosure with an ambient sound-level-sensing microphone and weatherproof speaker. A Type B PPB assembly may be substituted with an APS PPB assembly enclosure, but must be less than 7 pounds, be less than 16" x 6" x 5, and fit the standard. Maximum diameter of the hole for passage of wiring must not exceed 1.125". Attachment to the pole must be with two (2) screws of diameter from ¼- to ⅜-inch suitable for use in tapped holes. Clear space between any two (2) holes in the post must be at least twice the diameter of the larger hole.
4. 5" x 7" R10-3b sign above each PPB.
5. Braille on Face Plate
6. Custom Audio Message Option
7. Black button cover color

The APS speakers and electronic equipment must be installed inside the APS PPB assembly enclosure. Speakers must not interfere with the PPB or its mounting hardware. Speaker grills must be located on the APS PPB assembly enclosure.

Electronic switches, a potentiometer, or a handheld device must be used to control and program the volume level and the messaging for the APS. Programming mechanism must be submitted to the Engineer upon successful APS installation.

The APS must:

1. Include a provision to enable and disable the APS operation.
2. Have a failsafe operation. In the event of APS failure, the pedestrian push buttons system puts in a constant call.
3. Provide information using:
 - a. Audible speech walk message plays when the PPB is pressed. The message must include the name of the street to be crossed associated with that push button. An example of the message is "*Peachtree, 'walk' sign is 'on' to cross Peachtree.*" The message must be repeated for the duration of the "walk" interval. The APS must include at least five (5) sound options to be played during the "walk" interval. The Engineer may field select the "walk" sound option. The message must be activated for use from the beginning of the "walk" interval. The message must have a percussive tone consisting of multiple frequencies with a dominant component of 880 Hz. If the tone is selected as the "message," it must repeat 8 to 10 ticks per second.
 - b. Push button information message provides the name of the street to be crossed associated with that push button. The message must play when the PPB is pressed. An example of the message is "*Wait to cross Howard at Grand. Wait.*"
 - c. Push button locator tone that clicks or beeps. The locator tone must come from the PPB and repeat at one (1) tone per second interval. Each tone has a maximum duration of 0.15 second. The locator tone volume must adjust in response to ambient sound and be audible up to twelve feet (12') from the push button or to the building line, whichever is less.
4. Bluetooth-enable device capable of communicating with Apple iOS app and Microsoft PC app.
5. Shelf-mount Central Control Unit (iCCU-S) features full BIU capability. Must have SDLC port. Must support up to eight (8) phase/channels.

Construction

Arrange, at Contractor's expense, to have a manufacturer's representative qualified to work on APS present whenever the equipment is installed, modified, connected, and reconnected.

The APS must not interfere with the controller assembly, the signal installation on signal standards, the pedestrian signal heads, or the terminal compartment blocks. The APS electronic control equipment must reside inside the APS PPB assembly and the controller cabinet.

Contractor is responsible for the compatibility of the components and for making the necessary calibration adjustment to deliver the performance specified. Contractor shall provide the equipment and hardware required to install, set up, calibrate, and verify the performance of the APS.

Upon successful completion of the APS installation, disable the APS operation.

APPENDIX A

LOCATION MAP

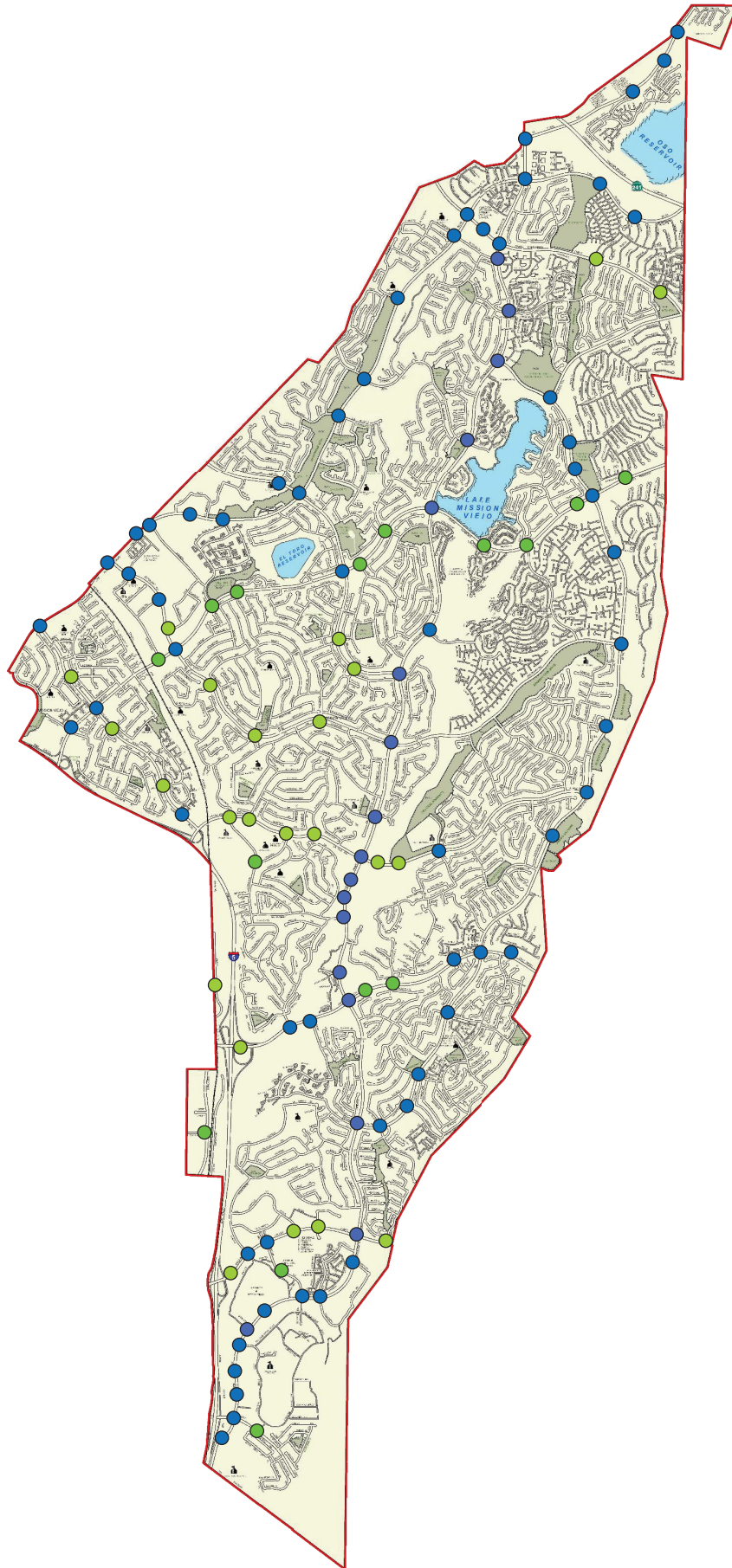

City of Mission Viejo – Traffic Signals With or Without Audible Pedestrian Push Buttons Systems

- Existing Traffic Signal Intersection Locations **WITHOUT** Audible Pedestrian Push Button Systems (24)
- Existing Traffic Signal Intersection Locations with existing Audible Pedestrian Push Button Systems (77)

APPENDIX B

APPLICABLE STANDARD PLANS

(Not Comprehensive — For Contractor's Convenience Only)

535

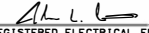
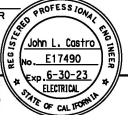
DIST	COUNTY	ROUTE	POST MILES TOTAL PROJECT	SHEET NO.	TOTAL SHEETS
 REGISTERED ELECTRICAL ENGINEER					
August 1, 2022 PLANS APPROVAL DATE					
					
<small>THE STATE OF CALIFORNIA OR ITS OFFICERS OR AGENTS SHALL NOT BE RESPONSIBLE FOR THE ACCURACY OR COMPLETENESS OF SCANNED COPIES OF THIS PLAN SHEET.</small>					

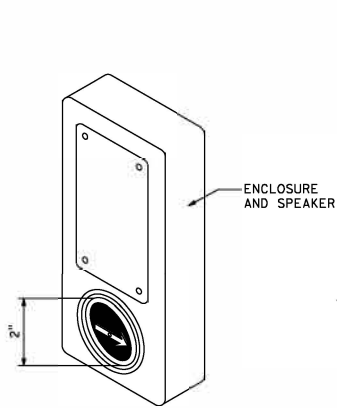

ACCESSIBLE PEDESTRIAN SIGNAL
DETAIL A

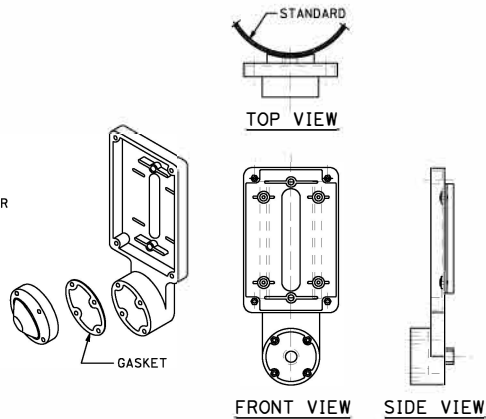

TYPE B PUSH BUTTON ASSEMBLY
DETAIL B

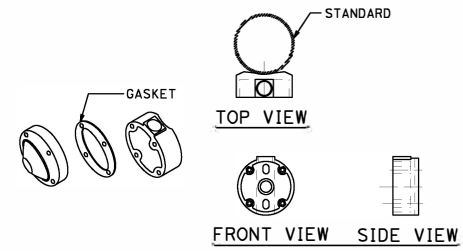

TYPE C PUSH BUTTON ASSEMBLY
DETAIL C

STATE OF CALIFORNIA
DEPARTMENT OF TRANSPORTATION
ELECTRICAL SYSTEMS
(ACCESSIBLE PEDESTRIAN SIGNAL
AND PUSH BUTTON ASSEMBLIES)
NO SCALE

ES-5C

2022 STANDARD PLAN ES-5C

8-24-22

[Return to Table of Contents](#)

APPENDIX C

EXCERPTS FROM STATE LABOR CODE

[Home](#)
[Bill Information](#)
[California Law](#)
[Publications](#)
[Other Resources](#)
[My Subscriptions](#)
[My Favorites](#)

 Code:

 Section:

[Up^](#) [Add To My Favorites](#)

LABOR CODE - LAB

DIVISION 2. EMPLOYMENT REGULATION AND SUPERVISION [200 - 2699.8] (*Division 2 enacted by Stats. 1937, Ch. 90.*)

PART 7. PUBLIC WORKS AND PUBLIC AGENCIES [1720 - 1964] (*Part 7 enacted by Stats. 1937, Ch. 90.*)

CHAPTER 1. Public Works [1720 - 1861] (*Chapter 1 enacted by Stats. 1937, Ch. 90.*)

ARTICLE 2. Wages [1770 - 1785] (*Article 2 enacted by Stats. 1937, Ch. 90.*)

1770. The Director of the Department of Industrial Relations shall determine the general prevailing rate of per diem wages in accordance with the standards set forth in Section 1773, and the director's determination in the matter shall be final except as provided in Section 1773.4. Nothing in this article, however, shall prohibit the payment of more than the general prevailing rate of wages to any worker employed on public work. This chapter does not permit any overtime work in violation of Article 3.

(Amended by Stats. 2017, Ch. 28, Sec. 17. (SB 96) Effective June 27, 2017.)

1771. Except for public works projects of one thousand dollars (\$1,000) or less, not less than the general prevailing rate of per diem wages for work of a similar character in the locality in which the public work is performed, and not less than the general prevailing rate of per diem wages for holiday and overtime work fixed as provided in this chapter, shall be paid to all workers employed on public works.

This section is applicable only to work performed under contract, and is not applicable to work carried out by a public agency with its own forces. This section is applicable to contracts let for maintenance work.

(Amended by Stats. 1981, Ch. 449, Sec. 1.)

1771.1. (a) A contractor or subcontractor shall not be qualified to bid on, be listed in a bid proposal, subject to the requirements of Section 4104 of the Public Contract Code, or engage in the performance of any contract for public work, as defined in this chapter, unless currently registered and qualified to perform public work pursuant to Section 1725.5. It is not a violation of this section for an unregistered contractor to submit a bid that is authorized by Section 7029.1 of the Business and Professions Code or by Section 10164 or 20103.5 of the Public Contract Code, provided the contractor is registered to perform public work pursuant to Section 1725.5 at the time the contract is awarded.

(b) Notice of the requirement described in subdivision (a) shall be included in all bid invitations and public works contracts, and a bid shall not be accepted nor any contract or subcontract entered into without proof of the contractor or subcontractor's current registration to perform public work pursuant to Section 1725.5.

(c) An inadvertent error in listing a subcontractor who is not registered pursuant to Section 1725.5 in a bid proposal shall not be grounds for filing a bid protest or grounds for considering the bid nonresponsive, provided that any of the following apply:

(1) The subcontractor is registered prior to the bid opening.

(2) Within 24 hours after the bid opening, the subcontractor is registered and has paid the penalty registration fee specified in subparagraph (E) of paragraph (2) of subdivision (a) of Section 1725.5.

(3) The subcontractor is replaced by another registered subcontractor pursuant to Section 4107 of the Public Contract Code.

(d) Failure by a subcontractor to be registered to perform public work as required by subdivision (a) shall be grounds under Section 4107 of the Public Contract Code for the contractor, with the consent of the awarding authority, to substitute a subcontractor who is registered to perform public work pursuant to Section 1725.5 in place of the unregistered subcontractor.

(e) The department shall maintain on its Internet Web site a list of contractors who are currently registered to perform public work pursuant to Section 1725.5.

(f) A contract entered into with any contractor or subcontractor in violation of subdivision (a) shall be subject to cancellation, provided that a contract for public work shall not be unlawful, void, or voidable solely due to the failure of the awarding body, contractor, or any subcontractor to comply with the requirements of Section 1725.5 or this section.

(g) If the Labor Commissioner or his or her designee determines that a contractor or subcontractor engaged in the performance of any public work contract without having been registered in accordance with this section, the contractor or subcontractor shall forfeit, as a civil penalty to the state, one hundred dollars (\$100) for each day of work performed in violation of the registration requirement, not to exceed an aggregate penalty of eight thousand dollars (\$8,000) in addition to any penalty registration fee assessed pursuant to clause (ii) of subparagraph (E) of paragraph (2) of subdivision (a) of Section 1725.5.

(h) (1) In addition to, or in lieu of, any other penalty or sanction authorized pursuant to this chapter, a higher tiered public works contractor or subcontractor who is found to have entered into a subcontract with an unregistered lower tier subcontractor to perform any public work in violation of the requirements of Section 1725.5 or this section shall be subject to forfeiture, as a civil penalty to the state, of one hundred dollars (\$100) for each day the unregistered lower tier subcontractor performs work in violation of the registration requirement, not to exceed an aggregate penalty of ten thousand dollars (\$10,000).

(2) The Labor Commissioner shall use the same standards specified in subparagraph (A) of paragraph (2) of subdivision (a) of Section 1775 when determining the severity of the violation and what penalty to assess, and may waive the penalty for a first time violation that was unintentional and did not hinder the Labor Commissioner's ability to monitor and enforce compliance with the requirements of this chapter.

(3) A higher tiered public works contractor or subcontractor shall not be liable for penalties assessed pursuant to paragraph (1) if the lower tier subcontractor's performance is in violation of the requirements of Section 1725.5 due to the revocation of a previously approved registration.

(4) A subcontractor shall not be liable for any penalties assessed against a higher tiered public works contractor or subcontractor pursuant to paragraph (1). A higher tiered public works contractor or subcontractor may not require a lower tiered subcontractor to indemnify or otherwise be liable for any penalties pursuant to paragraph (1).

(i) The Labor Commissioner or his or her designee shall issue a civil wage and penalty assessment, in accordance with the provisions of Section 1741, upon determination of penalties pursuant to subdivision (g) and subparagraph (B) of paragraph (1) of subdivision (h). Review of a civil wage and penalty assessment issued under this subdivision may be requested in accordance with the provisions of Section 1742. The regulations of the Director of Industrial Relations, which govern proceedings for review of civil wage and penalty assessments and the withholding of contract payments under Article 1 (commencing with Section 1720) and Article 2 (commencing with Section 1770), shall apply.

(j) (1) Where a contractor or subcontractor engages in the performance of any public work contract without having been registered in violation of the requirements of Section 1725.5 or this section, the Labor Commissioner shall issue and serve a stop order prohibiting the use of the unregistered contractor or the unregistered subcontractor on all public works until the unregistered contractor or unregistered subcontractor is registered. The stop order shall not apply to work by registered contractors or subcontractors on the public work.

(2) A stop order may be personally served upon the contractor or subcontractor by either of the following methods:

(A) Manual delivery of the order to the contractor or subcontractor personally.

(B) Leaving signed copies of the order with the person who is apparently in charge at the site of the public work and by thereafter mailing copies of the order by first class mail, postage prepaid to the contractor or subcontractor at one of the following:

(i) The address of the contractor or subcontractor on file with either the Secretary of State or the Contractors' State License Board.

(ii) If the contractor or subcontractor has no address on file with the Secretary of State or the Contractors' State License Board, the address of the site of the public work.

(3) The stop order shall be effective immediately upon service and shall be subject to appeal by the party contracting with the unregistered contractor or subcontractor, by the unregistered contractor or subcontractor, or both. The appeal, hearing, and any further review of the hearing decision shall be governed by the procedures, time limits, and other requirements specified in subdivision (a) of Section 238.1.

(4) Any employee of an unregistered contractor or subcontractor who is affected by a work stoppage ordered by the commissioner pursuant to this subdivision shall be paid at his or her regular hourly prevailing wage rate by that employer for any hours the employee would have worked but for the work stoppage, not to exceed 10 days.

(k) Failure of a contractor or subcontractor, owner, director, officer, or managing agent of the contractor or subcontractor to observe a stop order issued and served upon him or her pursuant to subdivision (j) is guilty of a misdemeanor punishable by imprisonment in county jail not exceeding 60 days or by a fine not exceeding ten thousand dollars (\$10,000), or both.

(l) This section shall apply to any bid proposal submitted on or after March 1, 2015, and any contract for public work entered into on or after April 1, 2015. This section shall also apply to the performance of any public work, as defined in this chapter, on or after January 1, 2018, regardless of when the contract for public work was entered.

(m) Penalties received pursuant to this section shall be deposited in the State Public Works Enforcement Fund established by Section 1771.3 and shall be used only for the purposes specified in that section.

(n) This section shall not apply to work performed on a public works project of twenty-five thousand dollars (\$25,000) or less when the project is for construction, alteration, demolition, installation, or repair work or to work performed on a public works project of fifteen thousand dollars (\$15,000) or less when the project is for maintenance work.

(Amended by Stats. 2018, Ch. 455, Sec. 2. (SB 877) Effective September 17, 2018.)

1771.2. (a) A joint labor-management committee established pursuant to the federal Labor Management Cooperation Act of 1978 (29 U.S.C. Sec. 175a) may bring an action in any court of competent jurisdiction against an employer that fails to pay the prevailing wage to its employees, as required by this article, or that fails to provide payroll records as required by Section 1776. This action shall be commenced not later than 18 months after the filing of a valid notice of completion in the office of the county recorder in each county in which the public work or some part thereof was performed, or not later than 18 months after acceptance of the public work, whichever occurs last.

(b) (1) In an action brought pursuant to this section, the court shall award restitution to an employee for unpaid wages, plus interest, under Section 3289 of the Civil Code from the date that the wages became due and payable, and liquidated damages equal to the amount of unpaid wages owed, and may impose civil penalties, only against an employer that failed to pay the prevailing wage to its employees, in accordance with Section 1775, injunctive relief, or any other appropriate form of equitable relief. The court shall follow the same standards and have the same discretion in setting the amount of penalties as are provided by subdivision (a) of Section 1775. The court shall award a prevailing joint labor-management committee its reasonable attorney's fees and costs incurred in maintaining the action, including expert witness fees.

(2) An action pursuant to this section shall not be based on the employer's misclassification of the craft of a worker in its certified payroll records.

(3) Liquidated damages shall be awarded only if the complaint alleges with specificity the wages due and unpaid to the individual workers, including how that amount was calculated, and the defendant fails to pay the wages, deposit that amount with the court to be held in escrow, or provide proof to the court of an adequate surety bond to cover the wages, within 60 days of service of the complaint. Liquidated damages shall be awarded only on the wages found to be due and unpaid. Additionally, if the defendant demonstrates to the satisfaction of the court that the defendant had substantial grounds for contesting that a portion of the allegedly unpaid wages were owed, the court may exercise its discretion to waive the payment of the liquidated damages with respect to that portion of the unpaid wages.

(4) This subdivision does not limit any other available remedies for a violation of this chapter.

(Amended by Stats. 2018, Ch. 682, Sec. 1. (AB 3231) Effective January 1, 2019.)

1771.3. (a) The State Public Works Enforcement Fund is hereby created as a special fund in the State Treasury to be available upon appropriation of the Legislature. All registration fees collected pursuant to Section 1725.5 and any other moneys as are designated by statute or order shall be deposited in the fund for the purposes specified in subdivision (b).

(b) Moneys in the State Public Works Enforcement Fund shall be used only for the following purposes:

- (1) The reasonable costs of administering the registration of contractors and subcontractors to perform public work pursuant to Section 1725.5.
- (2) The costs and obligations associated with the administration and enforcement of the requirements of this chapter by the Department of Industrial Relations.
- (3) The monitoring and enforcement of any requirement of this code by the Labor Commissioner on a public works project or in connection with the performance of public work as defined pursuant to this chapter.

(c) The annual contractor registration renewal fee specified in subdivision (a) of Section 1725.5, and any adjusted application or renewal fee, shall be set in amounts that are sufficient to support the annual appropriation approved by the Legislature for the State Public Works Enforcement Fund and not result in a fund balance greater than 25 percent of the appropriation. Any year-end balance in the fund greater than 25 percent of the appropriation shall be applied as a credit when determining any fee adjustments for the subsequent fiscal year.

(d) To provide adequate cashflow for the purposes specified in subdivision (b), the Director of Finance, with the concurrence of the Secretary of the Labor and Workforce Development Agency, may approve a short-term loan each fiscal year from the Labor Enforcement and Compliance Fund to the State Public Works Enforcement Fund.

- (1) The maximum amount of the annual loan allowable may be up to, but shall not exceed 50 percent of the appropriation authority of the State Public Works Enforcement Fund in the same year in which the loan was made.
- (2) For the purposes of this section, a "short-term loan" is a transfer that is made subject to both of the following conditions:
 - (A) Any amount loaned is to be repaid in full during the same fiscal year in which the loan was made, except that repayment may be delayed until a date not more than 30 days after the date of enactment of the annual Budget Act for the subsequent fiscal year.
 - (B) Loans shall be repaid whenever the funds are needed to meet cash expenditure needs in the loaning fund or account.

(Amended by Stats. 2017, Ch. 28, Sec. 19. (SB 96) Effective June 27, 2017.)

1771.4. (a) All of the following are applicable to all public works projects that are otherwise subject to the requirements of this chapter:

- (1) The call for bids and contract documents shall specify that the project is subject to compliance monitoring and enforcement by the Department of Industrial Relations.
- (2) The awarding body shall post or require the prime contractor to post job site notices, as prescribed by regulation.
- (3) (A) Each contractor and subcontractor shall furnish the records specified in Section 1776 directly to the Labor Commissioner, in the following manner:
 - (i) At least monthly or more frequently if specified in the contract with the awarding body. For purposes of this clause, "monthly" means that a submission of records shall be made at least once every 30 days while work is being performed on the project and within 30 days after the final day of work performed on the project.
 - (ii) In an electronic format, in the manner prescribed by the Labor Commissioner, on the department's internet website.
- (B) A contractor or subcontractor who fails to furnish records pursuant to subparagraph (A), relating to its employees, shall be subject to a penalty by the Labor Commissioner of one hundred dollars (\$100) per each day in which that party was in violation of subparagraph (A), not to exceed a total penalty of five thousand dollars (\$5,000) per project. Penalties received pursuant to this paragraph shall be deposited in the State Public Works Enforcement Fund established by Section 1771.3 and shall be used only for the purposes specified in that section.
- (C) The Labor Commissioner shall not levy a penalty pursuant to subparagraph (B) until a contractor or subcontractor fails to furnish the records pursuant to subparagraph (A) 14 days after the requirement set forth

in clause (i) of subparagraph (A).

(D) Penalties pursuant to subparagraph (B) may only accrue to the actual contractor or subcontractor that failed to furnish the records pursuant to subparagraph (A).

(4) If the contractor or subcontractor is not registered pursuant to Section 1725.5 and is performing work on a project for which registration is not required because of subdivision (f) of Section 1725.5, the unregistered contractor or subcontractor is not required to furnish the records specified in Section 1776 directly to the Labor Commissioner but shall retain the records specified in Section 1776 for at least three years after completion of the work.

(5) The department shall undertake those activities it deems necessary to monitor and enforce compliance with prevailing wage requirements.

(b) The Labor Commissioner may exempt a public works project from compliance with all or part of the requirements of subdivision (a) if either of the following occurs:

(1) The awarding body has enforced an approved labor compliance program, as defined in Section 1771.5, on all public works projects under its authority, except those deemed exempt pursuant to subdivision (a) of Section 1771.5, continuously since December 31, 2011.

(2) The awarding body has entered into a collective bargaining agreement that binds all contractors performing work on the project and that includes a mechanism for resolving disputes about the payment of wages.

(c) The requirements of paragraph (1) of subdivision (a) shall only apply to contracts for public works projects awarded on or after January 1, 2015.

(d) The requirements of paragraph (3) of subdivision (a) shall apply to all contracts for public work, whether new or ongoing, on or after January 1, 2016.

(Amended by Stats. 2021, Ch. 326, Sec. 1. (AB 1023) Effective January 1, 2022.)

1771.5. (a) Notwithstanding Section 1771, an awarding body may choose not to require the payment of the general prevailing rate of per diem wages or the general prevailing rate of per diem wages for holiday and overtime work for any public works project of twenty-five thousand dollars (\$25,000) or less when the project is for construction work, or for any public works project of fifteen thousand dollars (\$15,000) or less when the project is for alteration, demolition, repair, or maintenance work, if the awarding body has elected to initiate and has been approved by the Director of Industrial Relations to enforce a labor compliance program pursuant to subdivision (b) for every public works project under the authority of the awarding body.

(b) For purposes of this section, a labor compliance program shall include, but not be limited to, the following requirements:

(1) All bid invitations and public works contracts shall contain appropriate language concerning the requirements of this chapter.

(2) A prejob conference shall be conducted with the contractor and subcontractors to discuss federal and state labor law requirements applicable to the contract.

(3) Project contractors and subcontractors shall maintain and furnish, at a designated time, a certified copy of each weekly payroll containing a statement of compliance signed under penalty of perjury.

(4) The awarding body shall review, and, if appropriate, audit payroll records to verify compliance with this chapter.

(5) The awarding body shall withhold contract payments when payroll records are delinquent or inadequate.

(6) The awarding body shall withhold contract payments equal to the amount of underpayment and applicable penalties when, after investigation, it is established that underpayment has occurred.

(7) The awarding body shall comply with any other prevailing wage monitoring and enforcement activities that are required to be conducted by labor compliance programs by the Department of Industrial Relations.

(c) For purposes of this chapter, "labor compliance program" means a labor compliance program that is approved, as specified in state regulations, by the Director of Industrial Relations.

(d) For purposes of this chapter, the Director of Industrial Relations may revoke the approval of a labor compliance program in the manner specified in state regulations.

(Amended by Stats. 2014, Ch. 28, Sec. 67. (SB 854) Effective June 20, 2014.)

1771.6. (a) Any awarding body that enforces this chapter in accordance with Section 1726 or 1771.5 shall provide notice of the withholding of contract payments to the contractor and subcontractor, if applicable. The notice shall be in writing and shall describe the nature of the violation and the amount of wages, penalties, and forfeitures withheld. Service of the notice shall be completed pursuant to Section 1013 of the Code of Civil Procedure by first-class and certified mail to the contractor and subcontractor, if applicable. The notice shall advise the contractor and subcontractor, if applicable, of the procedure for obtaining review of the withholding of contract payments.

The awarding body shall also serve a copy of the notice by certified mail to any bonding company issuing a bond that secures the payment of wages covered by the notice and to any surety on a bond, if their identities are known to the awarding body.

(b) The withholding of contract payments in accordance with Section 1726 or 1771.5 shall be reviewable under Section 1742 in the same manner as if the notice of the withholding was a civil penalty order of the Labor Commissioner under this chapter. If review is requested, the Labor Commissioner may intervene to represent the awarding body.

(c) Pending a final order, or the expiration of the time period for seeking review of the notice of the withholding, the awarding body shall not disburse any contract payments withheld.

(d) From the amount recovered, the wage claim shall be satisfied prior to the amount being applied to penalties. If insufficient money is recovered to pay each worker in full, the money shall be prorated among all workers.

(e) Wages for workers who cannot be located shall be placed in the Industrial Relations Unpaid Wage Fund and held in trust for the workers pursuant to Section 96.7. Penalties shall be paid into the General Fund of the awarding body that has enforced this chapter pursuant to Section 1771.5.

(Repealed and added by Stats. 2000, Ch. 954, Sec. 16. Effective January 1, 2001. Operative July 1, 2001, by Sec. 21 of Ch. 954.)

1771.7. (a) (1) For contracts specified in subdivision (f), an awarding body that chooses to use funds derived from either the Kindergarten-University Public Education Facilities Bond Act of 2002 or the Kindergarten-University Public Education Facilities Bond Act of 2004 for a public works project, shall initiate and enforce, or contract with a third party to initiate and enforce, a labor compliance program, as described in subdivision (b) of Section 1771.5, with respect to that public works project.

(2) If an awarding body described in paragraph (1) chooses to contract with a third party to initiate and enforce a labor compliance program for a project described in paragraph (1), that third party shall not review the payroll records of its own employees or the employees of its subcontractors, and the awarding body or an independent third party shall review these payroll records for purposes of the labor compliance program.

(b) This section applies to public works that commence on or after April 1, 2003. For purposes of this subdivision, work performed during the design and preconstruction phases of construction, including, but not limited to, inspection and land surveying work, does not constitute the commencement of a public work.

(c) (1) For purposes of this section, if any campus of the California State University chooses to use the funds described in subdivision (a), then the "awarding body" is the Chancellor of the California State University. For purposes of this subdivision, if the chancellor is required by subdivision (a) to initiate and enforce, or to contract with a third party to initiate and enforce, a labor compliance program, then in addition to the requirements described in subdivision (b) of Section 1771.5, the Chancellor of the California State University shall review the payroll records on at least a monthly basis to ensure the awarding body's compliance with the labor compliance program.

(2) For purposes of this subdivision, if an awarding body described in subdivision (a) is the University of California or any campus of that university, and that awarding body is required by subdivision (a) to initiate and enforce, or to contract with a third party to initiate and enforce, a labor compliance program, then in addition to the requirements described in subdivision (b) of Section 1771.5, the payroll records shall be reviewed on at least a monthly basis to ensure the awarding body's compliance with the labor compliance program.

(d) (1) An awarding body described in subdivision (a) shall make a written finding that the awarding body has initiated and enforced, or has contracted with a third party to initiate and enforce, the labor compliance program described in subdivision (a).

(2) (A) If an awarding body described in subdivision (a) is a school district, the governing body of that district shall transmit to the State Allocation Board, in the manner determined by that board, a copy of the finding described in paragraph (1).

(B) The State Allocation Board shall not release the funds described in subdivision (a) to an awarding body that is a school district until the State Allocation Board has received the written finding described in paragraph (1).

(C) If the State Allocation Board conducts a postaward audit procedure with respect to an award of the funds described in subdivision (a) to an awarding body that is a school district, the State Allocation Board shall verify, in the manner determined by that board, that the school district has complied with the requirements of this subdivision.

(3) If an awarding body described in subdivision (a) is a community college district, the Chancellor of the California State University, or the office of the President of the University of California or any campus of the University of California, that awarding body shall transmit, in the manner determined by the Director of Industrial Relations, a copy of the finding described in paragraph (1) to the director of that department, or the director of any successor agency that is responsible for the oversight of employee wage and employee work hours laws.

(e) Because the reasonable costs directly related to monitoring and enforcing compliance with the prevailing wage requirements are necessary oversight activities, integral to the cost of construction of the public works projects, notwithstanding Section 17070.63 of the Education Code, the grant amounts as described in Chapter 12.5 (commencing with Section 17070.10) of Part 10 of Division 1 of Title 1 of the Education Code for the costs of a new construction or modernization project shall include the state's share of the reasonable and directly related costs of the labor compliance program used to monitor and enforce compliance with prevailing wage requirements.

(f) This section shall only apply to contracts awarded prior to January 1, 2012.

(Amended by Stats. 2014, Ch. 28, Sec. 68. (SB 854) Effective June 20, 2014.)

1772. Workers employed by contractors or subcontractors in the execution of any contract for public work are deemed to be employed upon public work.

(Amended by Stats. 1992, Ch. 1342, Sec. 7. Effective January 1, 1993.)

1773. The body awarding any contract for public work, or otherwise undertaking any public work, shall obtain the general prevailing rate of per diem wages and the general prevailing rate for holiday and overtime work in the locality in which the public work is to be performed for each craft, classification, or type of worker needed to execute the contract from the Director of Industrial Relations. The holidays upon which those rates shall be paid need not be specified by the awarding body, but shall be all holidays recognized in the applicable collective bargaining agreement. If the prevailing rate is not based on a collectively bargained rate, the holidays upon which the prevailing rate shall be paid shall be as provided in Section 6700 of the Government Code.

In determining the rates, the Director of Industrial Relations shall ascertain and consider the applicable wage rates established by collective bargaining agreements and the rates that may have been predetermined for federal public works, within the locality and in the nearest labor market area. Where the rates do not constitute the rates actually prevailing in the locality, the director shall obtain and consider further data from the labor organizations and employers or employer associations concerned, including the recognized collective bargaining representatives for the particular craft, classification, or type of work involved. The rate fixed for each craft, classification, or type of work shall be not less than the prevailing rate paid in the craft, classification, or type of work.

If the director determines that the rate of prevailing wage for any craft, classification, or type of worker is the rate established by a collective bargaining agreement, the director may adopt that rate by reference as provided for in the collective bargaining agreement and that determination shall be effective for the life of the agreement or until the director determines that another rate should be adopted.

(Amended by Stats. 1999, Ch. 30, Sec. 1. Effective January 1, 2000.)

1773.1. (a) Per diem wages, as the term is used in this chapter or in any other statute applicable to public works, includes employer payments for the following:

- (1) Health and welfare.
- (2) Pension.
- (3) Vacation.

(4) Travel.

(5) Subsistence.

(6) Apprenticeship or other training programs authorized by Section 3093, to the extent that the cost of training is reasonably related to the amount of the contributions.

(7) Worker protection and assistance programs or committees established under the federal Labor Management Cooperation Act of 1978 (29 U.S.C. Sec. 175a), to the extent that the activities of the programs or committees are directed to the monitoring and enforcement of laws related to public works.

(8) Industry advancement and collective bargaining agreements administrative fees, provided that these payments are made pursuant to a collective bargaining agreement to which the employer is obligated.

(9) Other purposes similar to those specified in paragraphs (1) to (5), inclusive; or other purposes similar to those specified in paragraphs (6) to (8), inclusive, if the payments are made pursuant to a collective bargaining agreement to which the employer is obligated.

(b) Employer payments include all of the following:

(1) The rate of contribution irrevocably made by the employer to a trustee or third person pursuant to a plan, fund, or program.

(2) The rate of actual costs to the employer reasonably anticipated in providing benefits to workers pursuant to an enforceable commitment to carry out a financially responsible plan or program communicated in writing to the workers affected.

(3) Payments to the California Apprenticeship Council pursuant to Section 1777.5.

(c) Employer payments are a credit against the obligation to pay the general prevailing rate of per diem wages. However, credit shall not be granted for benefits required to be provided by other state or federal law, for payments made to monitor and enforce laws related to public works if those payments are not made to a program or committee established under the federal Labor Management Cooperation Act of 1978 (29 U.S.C. Sec. 175a), or for payments for industry advancement and collective bargaining agreement administrative fees if those payments are not made pursuant to a collective bargaining agreement to which the employer is obligated. Credits for employer payments also shall not reduce the obligation to pay the hourly straight time or overtime wages found to be prevailing. However, an increased employer payment contribution that results in a lower hourly straight time or overtime wage shall not be considered a violation of the applicable prevailing wage determination if all of the following conditions are met:

(1) The increased employer payment is made pursuant to criteria set forth in a collective bargaining agreement.

(2) The basic hourly rate and increased employer payment are no less than the general prevailing rate of per diem wages and the general prevailing rate for holiday and overtime work in the director's general prevailing wage determination.

(3) The employer payment contribution is irrevocable unless made in error.

(d) An employer may take credit for an employer payment specified in subdivision (b), even if contributions are not made, or costs are not paid, during the same pay period for which credit is taken, if the employer regularly makes the contributions, or regularly pays the costs, for the plan, fund, or program on no less than a quarterly basis.

(e) The credit for employer payments shall be computed on an annualized basis when the employer seeks credit for employer payments that are higher for public works projects than for private construction performed by the same employer, unless one or more of the following occur:

(1) The employer has an enforceable obligation to make the higher rate of payments on future private construction performed by the employer.

(2) The higher rate of payments is required by a project labor agreement.

(3) The payments are made to the California Apprenticeship Council pursuant to Section 1777.5.

(4) The director determines that annualization would not serve the purposes of this chapter.

(f) (1) For the purpose of determining those per diem wages for contracts, the representative of any craft, classification, or type of worker needed to execute contracts shall file with the Department of Industrial Relations

fully executed copies of the collective bargaining agreements for the particular craft, classification, or type of work involved. The collective bargaining agreements shall be filed after their execution and thereafter may be taken into consideration pursuant to Section 1773 whenever they are filed 30 days prior to the call for bids. If the collective bargaining agreement has not been formalized, a typescript of the final draft may be filed temporarily, accompanied by a statement under penalty of perjury as to its effective date.

(2) When a copy of the collective bargaining agreement has previously been filed, fully executed copies of all modifications and extensions of the agreement that affect per diem wages or holidays shall be filed.

(3) The failure to comply with filing requirements of this subdivision shall not be grounds for setting aside a prevailing wage determination if the information taken into consideration is correct.

(Amended by Stats. 2016, Ch. 231, Sec. 1. (SB 954) Effective January 1, 2017.)

1773.2. The body awarding any contract for public work, or otherwise undertaking any public work, shall specify in the call for bids for the contract, and in the bid specifications and in the contract itself, what the general rate of per diem wages is for each craft, classification, or type of worker needed to execute the contract.

In lieu of specifying the rate of wages in the call for bids, and in the bid specifications and in the contract itself, the awarding body may, in the call for bids, bid specifications, and contract, include a statement that copies of the prevailing rate of per diem wages are on file at its principal office, which shall be made available to any interested party on request. The awarding body shall also cause a copy of the determination of the director of the prevailing rate of per diem wages to be posted at each job site.

(Amended by Stats. 1992, Ch. 1342, Sec. 8. Effective January 1, 1993.)

1773.3. (a) (1) An awarding body shall provide notice to the Department of Industrial Relations of any public works contract subject to the requirements of this chapter, within 30 days of the award, but in no event later than the first day in which a contractor has workers employed upon the public work.

(2) Notwithstanding paragraph (1) and subject to the discretion of the Labor Commissioner, an awarding body shall provide notice to the Department of Industrial Relations of any public works contract awarded pursuant to Section 10122, 20113, 20654, or 22050 of the Public Contract Code that is subject to the requirements of this chapter within 30 days after the award of the contract, but in no event later than the last day in which a contractor has workers employed upon the public work.

(3) The notice shall be transmitted electronically in a format specified by the department and shall include the name and registration number issued by the Department of Industrial Relations pursuant to Section 1725.5 of the contractor, the name and registration number issued by the Department of Industrial Relations pursuant to Section 1725.5 of any subcontractor listed on the successful bid, the bid and contract award dates, the contract amount, the estimated start and completion dates, jobsite location, and any additional information the department specifies that aids in the administration and enforcement of this chapter.

(b) In lieu of responding to any specific request for contract award information, the department may make the information provided by awarding bodies pursuant to this section available for public review on its Internet Web site.

(c) (1) An awarding body that fails to provide the notice required by subdivision (a) or that enters into a contract with or permits an unregistered contractor or subcontractor to engage in the performance of any public work in violation of the requirements of Section 1771.1, shall, in addition to any other sanction or penalty authorized by law, be subject to a civil penalty of one hundred dollars (\$100) for each day in violation of either requirement, not to exceed an aggregate penalty of ten thousand dollars (\$10,000) for each project.

(2) The Labor Commissioner shall use the same standards specified in subparagraph (A) of paragraph (2) of subdivision (a) of Section 1775 when determining the severity of the violation and what penalty to assess, and may waive the penalty for a first time violation that was unintentional and did not hinder the Labor Commissioner's ability to monitor and enforce compliance with the requirements of this chapter.

(d) An awarding body shall withhold final payment due to the contractor until at least 30 days after all of the required information in paragraph (2) of subdivision (a) has been submitted, including, but not limited to, providing a complete list of all subcontractors. If an awarding body makes a final payment to a contractor after that time and an unregistered contractor or subcontractor is found to have worked on the project, the awarding body shall be subject to a civil penalty assessed by the Labor Commissioner of one hundred dollars (\$100) for each full calendar day of noncompliance, for a period of up to 100 days, for each unregistered contractor or subcontractor.

(e) The Labor Commissioner may issue a citation for civil penalties to the awarding body pursuant to subdivisions (c) and (d). The citation shall be served pursuant to Section 1013 of the Code of Civil Procedure by first-class and certified mail.

(f) The procedure for the processing and appeal of a citation or civil penalty issued by the Labor Commissioner pursuant to this section shall be the same as that prescribed in Section 1023. For these purposes, "person" as used in Section 1023 shall include an awarding body.

(g) Whenever the Labor Commissioner determines that an awarding body has willfully violated the requirements of this section or chapter with respect to two or more public works contracts or projects in any 12-month period, the awarding body shall be ineligible to receive state funding or financial assistance for any construction project undertaken by or on behalf of the awarding body for one year, as defined by subdivision (d) of Section 1782. The debarment procedures adopted by the Labor Commissioner pursuant to Section 1777.1 shall apply to any determination made under this subdivision.

(h) A contractor or subcontractor shall not be liable for any penalties assessed against an awarding body pursuant to this section. An awarding body may not require a contractor or subcontractor to indemnify or otherwise be liable for any penalties assessed against an awarding body pursuant to this section.

(i) Penalties received pursuant to this section shall be deposited in the State Public Works Enforcement Fund established by Section 1771.3 and shall be used only for the purposes specified in that section.

(j) This section shall apply only if the public works contract is for a project of greater than twenty-five thousand dollars (\$25,000) when the project is for construction, alteration, demolition, installation, or repair work or if the public works contract is for a project of greater than fifteen thousand dollars (\$15,000) when the project is for maintenance work.

(Amended by Stats. 2018, Ch. 455, Sec. 3. (SB 877) Effective September 17, 2018.)

1773.4. Any prospective bidder or his representative, any representative of any craft, classification or type of workman involved, or the awarding body may, within 20 days after commencement of advertising of the call for bids by the awarding body, file with the Director of Industrial Relations a verified petition to review the determination of any such rate or rates upon the ground that they have not been determined in accordance with the provision of Section 1773 of this code. Within two days thereafter, a copy of such petition shall be filed with the awarding body. The petition shall set forth the facts upon which it is based. The Director of Industrial Relations or his authorized representative shall, upon notice to the petitioner, the awarding body and such other persons as he deems proper, including the recognized collective bargaining representatives for the particular crafts, classifications or types of work involved, institute an investigation or hold a hearing. Within 20 days after the filing of such petition, or within such longer period as agreed upon by the director, the awarding body, and all the interested parties, he shall make a determination and transmit the same in writing to the awarding body and to the interested parties.

Such determination shall be final and shall be the determination of the awarding body. Upon receipt by it of the notice of the filing of such petition the body awarding the contract or authorizing the public work shall extend the closing date for the submission of bids or the starting of work until five days after the determination of the general prevailing rates of per diem wages pursuant to this section.

Upon the filing of any such petition, notice thereof shall be set forth in the next and all subsequent publications by the awarding body of the call for bids. No other notice need be given to bidders by the awarding body by publication or otherwise. The determination of the director shall be included in the contract.

(Amended by Stats. 1969, Ch. 301.)

1773.5. (a) The Director of Industrial Relations may establish rules and regulations for the purpose of carrying out this chapter, including, but not limited to, the responsibilities and duties of awarding bodies under this chapter.

(b) When a request is made to the director for a determination of whether a specific project or type of work awarded or undertaken by a political subdivision is a public work, he or she shall make that determination within 60 days receipt of the last notice of support or opposition from any interested party relating to that project or type of work that was not unreasonably delayed, as determined by the director. If the director deems that the complexity of the request requires additional time to make that determination, the director may have up to an additional 60 days if he or she certifies in writing to the requestor, and any interested party, the reasons for the extension. If the requestor is not a political subdivision, the requestor shall, within 15 days of the request, serve a copy of the request upon the political subdivision, in which event the political subdivision shall, within 30 days of its receipt, advise the director of its position regarding the request. For projects or types of work that are otherwise private development projects receiving public funds, as specified in subdivision (b) of Section 1720, the director shall

determine whether a specific project or type of work is a public work within 120 days of receipt of the last notice of support or opposition relating to that project or type of work from any interested party that was not unreasonably delayed, as determined by the director.

(c) If an administrative appeal of the director's determination is made, it shall be made within 30 days of the date of the determination. The director shall issue a determination on the administrative appeal within 120 days after receipt of the last notice of support or opposition relating to that appeal from any interested party that was not unreasonably delayed, as determined by the director. The director may have up to an additional 60 days if he or she certifies in writing to the party requesting the appeal the reason for the extension.

(d) The director shall have quasi-legislative authority to determine coverage of projects or types of work under the prevailing wage laws of this chapter. A final determination on any administrative appeal is subject to judicial review pursuant to Section 1085 of the Code of Civil Procedure. These determinations, and any determinations relating to the general prevailing rate of per diem wages and the general prevailing rate for holiday, shift rate, and overtime work, shall be exempt from the Administrative Procedure Act (Chapter 3.5 (commencing with Section 11340) of Part 1 of Division 3 of Title 2 of the Government Code).

(Amended by Stats. 2013, Ch. 780, Sec. 3. (SB 377) Effective January 1, 2014.)

1773.6. If during any quarterly period the Director of Industrial Relations shall determine that there has been a change in any prevailing rate of per diem wages in any locality he or she shall make such change available to the awarding body and his or her determination shall be final. Such determination by the Director of Industrial Relations shall not be effective as to any contract for which the notice to bidders has been published.

(Amended by Stats. 2017, Ch. 28, Sec. 22. (SB 96) Effective June 27, 2017.)

1773.7. The provisions of Section 11250 of the Government Code shall not be applicable to Sections 1773, 1773.4, and 1773.6.

(Repealed and added by Stats. 1976, Ch. 281.)

1773.8. An increased employer payment contribution that results in a lower taxable wage shall not be considered a violation of the applicable prevailing wage determination so long as all of the following conditions are met:

- (a) The increased employer payment is made pursuant to criteria set forth in a collective bargaining agreement.
- (b) The increased employer payment and hourly straight time and overtime wage combined are no less than the general prevailing rate of per diem wages.
- (c) The employer payment contribution is irrevocable unless made in error.

(Added by Stats. 2012, Ch. 827, Sec. 2. (AB 2677) Effective January 1, 2013.)

1773.9. (a) The Director of Industrial Relations shall use the methodology set forth in subdivision (b) to determine the general prevailing rate of per diem wages in the locality in which the public work is to be performed.

(b) The general prevailing rate of per diem wages includes all of the following:

- (1) The basic hourly wage rate being paid to a majority of workers engaged in the particular craft, classification, or type of work within the locality and in the nearest labor market area, if a majority of the workers is paid at a single rate. If no single rate is being paid to a majority of the workers, then the single rate being paid to the greatest number of workers, or modal rate, is prevailing. If a modal rate cannot be determined, then the director shall establish an alternative rate, consistent with the methodology for determining the modal rate, by considering the appropriate collective bargaining agreements, federal rates, rates in the nearest labor market area, or other data such as wage survey data.
- (2) Other employer payments included in per diem wages pursuant to Section 1773.1 and as included as part of the total hourly wage rate from which the basic hourly wage rate was derived. In the event the total hourly wage rate does not include any employer payments, the director shall establish a prevailing employer payment rate by the same procedure set forth in paragraph (1).
- (3) The rate for holiday and overtime work shall be those rates specified in the collective bargaining agreement when the basic hourly rate is based on a collective bargaining agreement rate. In the event the basic hourly rate is not based on a collective bargaining agreement, the rate for holidays and overtime work, if any, included with the prevailing basic hourly rate of pay shall be prevailing.

(c) (1) If the director determines that the general prevailing rate of per diem wages is the rate established by a collective bargaining agreement, and that the collective bargaining agreement contains definite and predetermined changes during its term that will affect the rate adopted, the director shall incorporate those changes into the determination. Predetermined changes that are rescinded prior to their effective date shall not be enforced.

(2) When the director determines that there is a definite and predetermined change in the general prevailing rate of per diem wages as described in paragraph (1), but has not published, at the time of the effective date of the predetermined change, the allocation of the predetermined change as between the basic hourly wage and other employer payments included in per diem wages pursuant to Section 1773.1, a contractor or subcontractor may allocate payments of not less than the amount of the definite and predetermined change to either the basic hourly wage or other employer payments included in per diem wages for up to 60 days following the director's publication of the specific allocation of the predetermined change.

(3) When the director determines that there is a definite and predetermined change in the general prevailing rate of per diem wages as described in paragraph (1), but the allocation of that predetermined change as between the basic hourly wage and other employer payments included in per diem wages pursuant to Section 1773.1 is subsequently altered by the parties to a collective bargaining agreement described in paragraph (1), a contractor or subcontractor may allocate payments of not less than the amount of the definite and predetermined change in accordance with either the originally published allocation or the allocation as altered in the collective bargaining agreement.

(Amended by Stats. 2007, Ch. 482, Sec. 2. Effective January 1, 2008.)

1773.11. (a) Notwithstanding any other provision of law and except as otherwise provided by this section, if the state or a political subdivision thereof agrees by contract with a private entity that the private entity's employees receive, in performing that contract, the general prevailing rate of per diem wages and the general prevailing rate for holiday and overtime work, the director shall, upon a request by the state or the political subdivision, do both of the following:

(1) Determine, as otherwise provided by law, the wage rates for each craft, classification, or type of worker that are needed to execute the contract.

(2) Provide these wage rates to the state or political subdivision that requests them.

(b) This section does not apply to a contract for a public work, as defined in this chapter.

(c) The director shall determine and provide the wage rates described in this section in the order in which the requests for these wage rates were received and regardless of the calendar year in which they were received. If there are more than 20 pending requests in a calendar year, the director shall respond only to the first 20 requests in the order in which they were received. If the director determines that funding is available in any calendar year to determine and provide these wage rates in response to more than 20 requests, the director shall respond to these requests in a manner consistent with this subdivision.

(Added by Stats. 2003, Ch. 343, Sec. 1. Effective January 1, 2004.)

1774. The contractor to whom the contract is awarded, and any subcontractor under him, shall pay not less than the specified prevailing rates of wages to all workmen employed in the execution of the contract.

(Enacted by Stats. 1937, Ch. 90.)

1775. (a) (1) The contractor and any subcontractor under the contractor shall, as a penalty to the state or political subdivision on whose behalf the contract is made or awarded, forfeit not more than two hundred dollars (\$200) for each calendar day, or portion thereof, for each worker paid less than the prevailing wage rates as determined by the director for the work or craft in which the worker is employed for any public work done under the contract by the contractor or, except as provided in subdivision (b), by any subcontractor under the contractor.

(2) (A) The amount of the penalty shall be determined by the Labor Commissioner based on consideration of both of the following:

(i) Whether the failure of the contractor or subcontractor to pay the correct rate of per diem wages was a good faith mistake and, if so, the error was promptly and voluntarily corrected when brought to the attention of the contractor or subcontractor.

(ii) Whether the contractor or subcontractor has a prior record of failing to meet its prevailing wage obligations.

(B) (i) The penalty may not be less than forty dollars (\$40) for each calendar day, or portion thereof, for each worker paid less than the prevailing wage rate, unless the failure of the contractor or subcontractor to pay the correct rate of per diem wages was a good faith mistake and, if so, the error was promptly and voluntarily corrected when brought to the attention of the contractor or subcontractor.

(ii) The penalty may not be less than eighty dollars (\$80) for each calendar day, or portion thereof, for each worker paid less than the prevailing wage rate, if the contractor or subcontractor has been assessed penalties within the previous three years for failing to meet its prevailing wage obligations on a separate contract, unless those penalties were subsequently withdrawn or overturned.

(iii) The penalty may not be less than one hundred twenty dollars (\$120) for each calendar day, or portion thereof, for each worker paid less than the prevailing wage rate, if the Labor Commissioner determines that the violation was willful, as defined in subdivision (c) of Section 1777.1.

(C) If the amount due under this section is collected from the contractor or subcontractor, any outstanding wage claim under Chapter 1 (commencing with Section 1720) of Part 7 of Division 2 against that contractor or subcontractor shall be satisfied before applying that amount to the penalty imposed on that contractor or subcontractor pursuant to this section.

(D) The determination of the Labor Commissioner as to the amount of the penalty shall be reviewable only for abuse of discretion.

(E) The difference between the prevailing wage rates and the amount paid to each worker for each calendar day or portion thereof for which each worker was paid less than the prevailing wage rate shall be paid to each worker by the contractor or subcontractor, and the body awarding the contract shall cause to be inserted in the contract a stipulation that this section will be complied with.

(b) If a worker employed by a subcontractor on a public works project is not paid the general prevailing rate of per diem wages by the subcontractor, the prime contractor of the project is not liable for any penalties under subdivision (a) unless the prime contractor had knowledge of that failure of the subcontractor to pay the specified prevailing rate of wages to those workers or unless the prime contractor fails to comply with all of the following requirements:

(1) The contract executed between the contractor and the subcontractor for the performance of work on the public works project shall include a copy of the provisions of this section and Sections 1771, 1776, 1777.5, 1813, and 1815.

(2) The contractor shall monitor the payment of the specified general prevailing rate of per diem wages by the subcontractor to the employees, by periodic review of the certified payroll records of the subcontractor.

(3) Upon becoming aware of the failure of the subcontractor to pay his or her workers the specified prevailing rate of wages, the contractor shall diligently take corrective action to halt or rectify the failure, including, but not limited to, retaining sufficient funds due the subcontractor for work performed on the public works project.

(4) Prior to making final payment to the subcontractor for work performed on the public works project, the contractor shall obtain an affidavit signed under penalty of perjury from the subcontractor that the subcontractor has paid the specified general prevailing rate of per diem wages to his or her employees on the public works project and any amounts due pursuant to Section 1813.

(c) The Division of Labor Standards Enforcement shall notify the contractor on a public works project within 15 days of the receipt by the Division of Labor Standards Enforcement of a complaint of the failure of a subcontractor on that public works project to pay workers the general prevailing rate of per diem wages.

(Amended by Stats. 2011, Ch. 677, Sec. 1. (AB 551) Effective January 1, 2012.)

1776. (a) Each contractor and subcontractor shall keep accurate payroll records, showing the name, address, social security number, work classification, straight time and overtime hours worked each day and week, and the actual per diem wages paid to each journeyman, apprentice, worker, or other employee employed by him or her in connection with the public work. Each payroll record shall contain or be verified by a written declaration that it is made under penalty of perjury, stating both of the following:

(1) The information contained in the payroll record is true and correct.

(2) The employer has complied with the requirements of Sections 1771, 1811, and 1815 for any work performed by his or her employees on the public works project.

(b) The payroll records enumerated under subdivision (a) shall be certified and shall be available for inspection at all reasonable hours at the principal office of the contractor on the following basis:

(1) A certified copy of an employee's payroll record shall be made available for inspection or furnished to the employee or his or her authorized representative on request.

(2) A certified copy of all payroll records enumerated in subdivision (a) shall be made available for inspection or furnished upon request to a representative of the body awarding the contract and the Division of Labor Standards Enforcement of the Department of Industrial Relations.

(3) A certified copy of all payroll records enumerated in subdivision (a) shall be made available upon request by the public for inspection or for copies thereof. However, a request by the public shall be made through either the body awarding the contract or the Division of Labor Standards Enforcement. If the requested payroll records have not been provided pursuant to paragraph (2), the requesting party shall, prior to being provided the records, reimburse the costs of preparation by the contractor, subcontractors, and the entity through which the request was made. The public may not be given access to the records at the principal office of the contractor.

(c) Unless required to be furnished directly to the Labor Commissioner in accordance with paragraph (3) of subdivision (a) of Section 1771.4, the certified payroll records shall be on forms provided by the Division of Labor Standards Enforcement or shall contain the same information as the forms provided by the division. The payroll records may consist of printouts of payroll data that are maintained as computer records, if the printouts contain the same information as the forms provided by the division and the printouts are verified in the manner specified in subdivision (a).

(d) A contractor or subcontractor shall file a certified copy of the records enumerated in subdivision (a) with the entity that requested the records within 10 days after receipt of a written request.

(e) Except as provided in subdivision (f), any copy of records made available for inspection as copies and furnished upon request to the public or any public agency by the awarding body or the Division of Labor Standards Enforcement shall be marked or obliterated to prevent disclosure of an individual's name, address, and social security number. The name and address of the contractor awarded the contract or the subcontractor performing the contract shall not be marked or obliterated. Any copy of records made available for inspection by, or furnished to, a multiemployer Taft-Hartley trust fund (29 U.S.C. Sec. 186(c)(5)) that requests the records for the purposes of allocating contributions to participants shall be marked or obliterated only to prevent disclosure of an individual's full social security number, but shall provide the last four digits of the social security number. Any copy of records made available for inspection by, or furnished to, a joint labor-management committee established pursuant to the federal Labor Management Cooperation Act of 1978 (29 U.S.C. Sec. 175a) shall be marked or obliterated only to prevent disclosure of an individual's social security number.

(f) (1) Notwithstanding any other provision of law, agencies that are included in the Joint Enforcement Strike Force on the Underground Economy established pursuant to Section 329 of the Unemployment Insurance Code and other law enforcement agencies investigating violations of law shall, upon request, be provided nonredacted copies of certified payroll records. Any copies of records or certified payroll made available for inspection and furnished upon request to the public by an agency included in the Joint Enforcement Strike Force on the Underground Economy or to a law enforcement agency investigating a violation of law shall be marked or redacted to prevent disclosure of an individual's name, address, and social security number.

(2) An employer shall not be liable for damages in a civil action for any reasonable act or omission taken in good faith in compliance with this subdivision.

(g) The contractor shall inform the body awarding the contract of the location of the records enumerated under subdivision (a), including the street address, city, and county, and shall, within five working days, provide a notice of a change of location and address.

(h) The contractor or subcontractor has 10 days in which to comply subsequent to receipt of a written notice requesting the records enumerated in subdivision (a). In the event that the contractor or subcontractor fails to comply within the 10-day period, he or she shall, as a penalty to the state or political subdivision on whose behalf the contract is made or awarded, forfeit one hundred dollars (\$100) for each calendar day, or portion thereof, for each worker, until strict compliance is effectuated. Upon the request of the Division of Labor Standards Enforcement, these penalties shall be withheld from progress payments then due. A contractor is not subject to a penalty assessment pursuant to this section due to the failure of a subcontractor to comply with this section.

(i) The body awarding the contract shall cause to be inserted in the contract stipulations to effectuate this section.

(j) The director shall adopt rules consistent with the California Public Records Act (Chapter 3.5 (commencing with Section 6250) of Division 7 of Title 1 of the Government Code) and the Information Practices Act of 1977 (Title 1.8

(commencing with Section 1798) of Part 4 of Division 3 of the Civil Code) governing the release of these records, including the establishment of reasonable fees to be charged for reproducing copies of records required by this section.

(Amended by Stats. 2014, Ch. 28, Sec. 71. (SB 854) Effective June 20, 2014. Superseded on January 1, 2023; see amendment by Stats. 2021, Ch. 615.)

1776. (a) Each contractor and subcontractor shall keep accurate payroll records, showing the name, address, social security number, work classification, straight time and overtime hours worked each day and week, and the actual per diem wages paid to each journeyman, apprentice, worker, or other employee employed by the contractor or subcontractor in connection with the public work. Each payroll record shall contain or be verified by a written declaration that it is made under penalty of perjury, stating both of the following:

(1) The information contained in the payroll record is true and correct.

(2) The employer has complied with the requirements of Sections 1771, 1811, and 1815 for any work performed by that person's employees on the public works project.

(b) The payroll records enumerated under subdivision (a) shall be certified and shall be available for inspection at all reasonable hours at the principal office of the contractor on the following basis:

(1) A certified copy of an employee's payroll record shall be made available for inspection or furnished to the employee or the employee's authorized representative on request.

(2) A certified copy of all payroll records enumerated in subdivision (a) shall be made available for inspection or furnished upon request to a representative of the body awarding the contract and the Division of Labor Standards Enforcement of the Department of Industrial Relations.

(3) A certified copy of all payroll records enumerated in subdivision (a) shall be made available upon request by the public for inspection or for copies thereof. However, a request by the public shall be made through either the body awarding the contract or the Division of Labor Standards Enforcement. If the requested payroll records have not been provided pursuant to paragraph (2), the requesting party shall, prior to being provided the records, reimburse the costs of preparation by the contractor, subcontractors, and the entity through which the request was made. The public may not be given access to the records at the principal office of the contractor.

(c) Unless required to be furnished directly to the Labor Commissioner in accordance with paragraph (3) of subdivision (a) of Section 1771.4, the certified payroll records shall be on forms provided by the Division of Labor Standards Enforcement or shall contain the same information as the forms provided by the division. The payroll records may consist of printouts of payroll data that are maintained as computer records, if the printouts contain the same information as the forms provided by the division and the printouts are verified in the manner specified in subdivision (a).

(d) A contractor or subcontractor shall file a certified copy of the records enumerated in subdivision (a) with the entity that requested the records within 10 days after receipt of a written request.

(e) Except as provided in subdivision (f), any copy of records made available for inspection as copies and furnished upon request to the public or any public agency by the awarding body or the Division of Labor Standards Enforcement shall be marked or obliterated to prevent disclosure of an individual's name, address, and social security number. The name and address of the contractor awarded the contract or the subcontractor performing the contract shall not be marked or obliterated. Any copy of records made available for inspection by, or furnished to, a multiemployer Taft-Hartley trust fund (29 U.S.C. Sec. 186(c)(5)) that requests the records for the purposes of allocating contributions to participants shall be marked or obliterated only to prevent disclosure of an individual's full social security number, but shall provide the last four digits of the social security number. Any copy of records made available for inspection by, or furnished to, a joint labor-management committee established pursuant to the federal Labor Management Cooperation Act of 1978 (29 U.S.C. Sec. 175a) shall be marked or obliterated only to prevent disclosure of an individual's social security number.

(f) (1) Notwithstanding any other provision of law, agencies that are included in the Joint Enforcement Strike Force on the Underground Economy established pursuant to Section 329 of the Unemployment Insurance Code and other law enforcement agencies investigating violations of law shall, upon request, be provided nonredacted copies of certified payroll records. Any copies of records or certified payroll made available for inspection and furnished upon request to the public by an agency included in the Joint Enforcement Strike Force on the Underground Economy or to a law enforcement agency investigating a violation of law shall be marked or redacted to prevent disclosure of an individual's name, address, and social security number.

(2) An employer shall not be liable for damages in a civil action for any reasonable act or omission taken in good faith in compliance with this subdivision.

(g) The contractor shall inform the body awarding the contract of the location of the records enumerated under subdivision (a), including the street address, city, and county, and shall, within five working days, provide a notice of a change of location and address.

(h) The contractor or subcontractor has 10 days in which to comply subsequent to receipt of a written notice requesting the records enumerated in subdivision (a). In the event that the contractor or subcontractor fails to comply within the 10-day period, the contractor or subcontractor shall, as a penalty to the state or political subdivision on whose behalf the contract is made or awarded, forfeit one hundred dollars (\$100) for each calendar day, or portion thereof, for each worker, until strict compliance is effectuated. Upon the request of the Division of Labor Standards Enforcement, these penalties shall be withheld from progress payments then due. A contractor is not subject to a penalty assessment pursuant to this section due to the failure of a subcontractor to comply with this section.

(i) The body awarding the contract shall cause to be inserted in the contract stipulations to effectuate this section.

(j) The director shall adopt rules consistent with the California Public Records Act (Division 10 (commencing with Section 7920.000) of Title 1 of the Government Code) and the Information Practices Act of 1977 (Title 1.8 (commencing with Section 1798) of Part 4 of Division 3 of the Civil Code) governing the release of these records, including the establishment of reasonable fees to be charged for reproducing copies of records required by this section.

(Amended by Stats. 2021, Ch. 615, Sec. 321. (AB 474) Effective January 1, 2022. Operative January 1, 2023, pursuant to Sec. 463 of Stats. 2021, Ch. 615.)

1777. Any officer, agent, or representative of the State or of any political subdivision who wilfully violates any provision of this article, and any contractor, or subcontractor, or agent or representative thereof, doing public work who neglects to comply with any provision of section 1776 is guilty of a misdemeanor.

(Enacted by Stats. 1937, Ch. 90.)

1777.1. (a) Whenever a contractor or subcontractor performing a public works project pursuant to this chapter is found by the Labor Commissioner to be in violation of this chapter with intent to defraud, the contractor or subcontractor or a firm, corporation, partnership, or association in which the contractor or subcontractor has any interest is ineligible for a period of not less than one year or more than three years to do either of the following:

- (1) Bid on or be awarded a contract for a public works project.
- (2) Perform work as a subcontractor on a public works project.

(b) Whenever a contractor or subcontractor performing a public works project pursuant to this chapter is found by the Labor Commissioner to have committed two or more separate willful violations of this chapter within a three-year period, the contractor or subcontractor or a firm, corporation, partnership, or association in which the contractor or subcontractor has any interest is ineligible for a period up to three years to do either of the following:

- (1) Bid on or be awarded a contract for a public works project.
- (2) Perform work as a subcontractor on a public works project.

(c) Whenever a contractor or subcontractor performing a public works project has failed to provide a timely response to a request by the Division of Labor Standards Enforcement, the Division of Apprenticeship Standards, or the awarding body to produce certified payroll records pursuant to Section 1776, the Labor Commissioner shall notify the contractor or subcontractor that, in addition to any other penalties provided by law, the contractor or subcontractor will be subject to debarment under this section if the certified payroll records are not produced within 30 days after receipt of the written notice. If the commissioner finds that the contractor or subcontractor has failed to comply with Section 1776 by that deadline, unless the commissioner finds that the failure to comply was due to circumstances outside the contractor's or subcontractor's control, the contractor or subcontractor or a firm, corporation, partnership, or association in which the contractor or subcontractor has any interest is ineligible for a period of not less than one year and not more than three years to do either of the following:

- (1) Bid on or be awarded a contract for a public works project.
- (2) Perform work as a subcontractor on a public works project.

(d) (1) In the event a contractor or subcontractor is determined by the Labor Commissioner to have knowingly committed a serious violation of any provision of Section 1777.5, the Labor Commissioner may also deny to the contractor or subcontractor, and to its responsible officers, the right to bid on or to be awarded or perform work as a subcontractor on any public works contract for a period of up to one year for the first violation and for a period of up to three years for a second or subsequent violation. Each period of debarment shall run from the date the determination of noncompliance by the Labor Commissioner becomes a final order.

(2) The Labor Commissioner shall consider, in determining whether a violation is serious, and in determining whether and for how long a party should be debarred for violating Section 1777.5, all of the following circumstances:

(A) Whether the violation was intentional.

(B) Whether the party has committed other violations of Section 1777.5.

(C) Whether, upon notice of the violation, the party took steps to voluntarily remedy the violation.

(D) Whether, and to what extent, the violation resulted in lost training opportunities for apprentices.

(E) Whether, and to what extent, the violation otherwise harmed apprentices or apprenticeship programs.

(e) A willful violation occurs when the contractor or subcontractor knew or reasonably should have known of his or her obligations under the public works law and deliberately fails or deliberately refuses to comply with its provisions.

(f) The Labor Commissioner shall publish on the commissioner's Internet Web site a list of contractors who are ineligible to bid on or be awarded a public works contract, or to perform work as a subcontractor on a public works project pursuant to this chapter. The list shall contain the name of the contractor, the Contractors' State License Board license number of the contractor, and the effective period of debarment of the contractor. Contractors shall be added to the list upon issuance of a debarment order and the commissioner shall also notify the Contractors' State License Board when the list is updated. At least annually, the commissioner shall notify awarding bodies of the availability of the list of debarred contractors. The commissioner shall also place advertisements in construction industry publications targeted to the contractors and subcontractors, chosen by the commissioner, that state the effective period of the debarment and the reason for debarment. The advertisements shall appear one time for each debarment of a contractor in each publication chosen by the commissioner. The debarred contractor or subcontractor shall be liable to the commissioner for the reasonable cost of the advertisements, not to exceed five thousand dollars (\$5,000). The amount paid to the commissioner for the advertisements shall be credited against the contractor's or subcontractor's obligation to pay civil fines or penalties for the same willful violation of this chapter.

(g) For purposes of this section, "contractor or subcontractor" means a firm, corporation, partnership, or association and its responsible managing officer, as well as any supervisors, managers, and officers found by the Labor Commissioner to be personally and substantially responsible for the willful violation of this chapter.

(h) For the purposes of this section, the term "any interest" means an interest in the entity bidding or performing work on the public works project, whether as an owner, partner, officer, manager, employee, agent, consultant, or representative. "Any interest" includes, but is not limited to, all instances where the debarred contractor or subcontractor receives payments, whether cash or any other form of compensation, from any entity bidding or performing work on the public works project, or enters into any contracts or agreements with the entity bidding or performing work on the public works project for services performed or to be performed for contracts that have been or will be assigned or sublet, or for vehicles, tools, equipment, or supplies that have been or will be sold, rented, or leased during the period from the initiation of the debarment proceedings until the end of the term of the debarment period. "Any interest" does not include shares held in a publicly traded corporation if the shares were not received as compensation after the initiation of debarment from an entity bidding or performing work on a public works project.

(i) For the purposes of this section, the term "entity" is defined as a company, limited liability company, association, partnership, sole proprietorship, limited liability partnership, corporation, business trust, or organization.

(j) The Labor Commissioner shall adopt rules and regulations for the administration and enforcement of this section.

(Amended by Stats. 2014, Ch. 297, Sec. 1. (AB 2744) Effective January 1, 2015.)

1777.5. (a) (1) This chapter does not prevent the employment upon public works of properly registered apprentices who are active participants in an approved apprenticeship program.

(2) For purposes of this chapter, "apprenticeship program" means a program under the jurisdiction of the California Apprenticeship Council established pursuant to Section 3070.

(b) (1) Every apprentice employed upon public works shall be paid the prevailing rate of per diem wages for apprentices in the trade to which he or she is registered and shall be employed only at the work of the craft or trade to which he or she is registered.

(2) Unless otherwise provided by a collective bargaining agreement, when a contractor requests the dispatch of an apprentice pursuant to this section to perform work on a public works project and requires the apprentice to fill out an application or undergo testing, training, an examination, or other preemployment process as a condition of employment, the apprentice shall be paid for the time spent on the required preemployment activity, including travel time to and from the required activity, if any, at the prevailing rate of per diem wages for apprentices in the trade to which he or she is registered. Unless otherwise provided by a collective bargaining agreement, a contractor is not required to compensate an apprentice for the time spent on preemployment activities if the apprentice is required to take a preemployment drug or alcohol test and he or she fails to pass that test.

(c) Only apprentices, as defined in Section 3077, who are in training under apprenticeship standards that have been approved by the Chief of the Division of Apprenticeship Standards and who are parties to written apprentice agreements under Chapter 4 (commencing with Section 3070) of Division 3 are eligible to be employed at the apprentice wage rate on public works. The employment and training of each apprentice shall be in accordance with either of the following:

(1) The apprenticeship standards and apprentice agreements under which he or she is training.

(2) The rules and regulations of the California Apprenticeship Council.

(d) If the contractor to whom the contract is awarded by the state or any political subdivision, in performing any of the work under the contract, employs workers in any apprenticeable craft or trade, the contractor shall employ apprentices in at least the ratio set forth in this section and may apply to any apprenticeship program in the craft or trade that can provide apprentices to the site of the public work for a certificate approving the contractor under the apprenticeship standards for the employment and training of apprentices in the area or industry affected. However, the decision of the apprenticeship program to approve or deny a certificate shall be subject to review by the Administrator of Apprenticeship. The apprenticeship program or programs, upon approving the contractor, shall arrange for the dispatch of apprentices to the contractor. A contractor covered by an apprenticeship program's standards shall not be required to submit any additional application in order to include additional public works contracts under that program. "Apprenticeable craft or trade," as used in this section, means a craft or trade determined as an apprenticeable occupation in accordance with rules and regulations prescribed by the California Apprenticeship Council. As used in this section, "contractor" includes any subcontractor under a contractor who performs any public works not excluded by subdivision (o).

(e) Before commencing work on a contract for public works, every contractor shall submit contract award information to an applicable apprenticeship program that can supply apprentices to the site of the public work. The information submitted shall include an estimate of journeyman hours to be performed under the contract, the number of apprentices proposed to be employed, and the approximate dates the apprentices would be employed. A copy of this information shall also be submitted to the awarding body, if requested by the awarding body. Within 60 days after concluding work on the contract, each contractor and subcontractor shall submit to the awarding body, if requested, and to the apprenticeship program a verified statement of the journeyman and apprentice hours performed on the contract. The information under this subdivision shall be public. The apprenticeship programs shall retain this information for 12 months.

(f) The apprenticeship program supplying apprentices to the area of the site of the public work shall ensure equal employment and affirmative action in apprenticeship for women and minorities.

(g) The ratio of work performed by apprentices to journeymen employed in a particular craft or trade on the public work may be no higher than the ratio stipulated in the apprenticeship standards under which the apprenticeship program operates if the contractor agrees to be bound by those standards. However, except as otherwise provided in this section, in no case shall the ratio be less than one hour of apprentice work for every five hours of journeyman work.

(h) This ratio of apprentice work to journeyman work shall apply during any day or portion of a day when any journeyman is employed at the jobsite and shall be computed on the basis of the hours worked during the day by journeymen so employed. Any work performed by a journeyman in excess of eight hours per day or 40 hours per week shall not be used to calculate the ratio. The contractor shall employ apprentices for the number of hours computed as above before the end of the contract or, in the case of a subcontractor, before the end of the

subcontract. However, the contractor shall endeavor, to the greatest extent possible, to employ apprentices during the same time period that the journeymen in the same craft or trade are employed at the jobsite. When an hourly apprenticeship ratio is not feasible for a particular craft or trade, the Administrator of Apprenticeship, upon application of an apprenticeship program, may order a minimum ratio of not less than one apprentice for each five journeymen in a craft or trade classification.

(i) A contractor covered by this section who has agreed to be covered by an apprenticeship program's standards upon the issuance of the approval certificate, or who has been previously approved for an apprenticeship program in the craft or trade, shall employ the number of apprentices or the ratio of apprentices to journeymen stipulated in the applicable apprenticeship standards, but in no event less than the 1-to-5 ratio required by subdivision (g).

(j) Upon proper showing by a contractor that he or she employs apprentices in a particular craft or trade in the state on all of his or her contracts on an annual average of not less than one hour of apprentice work for every five hours of labor performed by journeymen, the Administrator of Apprenticeship may grant a certificate exempting the contractor from the 1-to-5 hourly ratio, as set forth in this section for that craft or trade.

(k) An apprenticeship program has the discretion to grant to a participating contractor or contractor association a certificate, which shall be subject to the approval of the Administrator of Apprenticeship, exempting the contractor from the 1-to-5 ratio set forth in this section when it finds that any one of the following conditions is met:

(1) Unemployment for the previous three-month period in the area exceeds an average of 15 percent.

(2) The number of apprentices in training in the area exceeds a ratio of 1 to 5.

(3) There is a showing that the apprenticeable craft or trade is replacing at least one-thirtieth of its journeymen annually through apprenticeship training, either on a statewide basis or on a local basis.

(4) Assignment of an apprentice to any work performed under a public works contract would create a condition that would jeopardize his or her life or the life, safety, or property of fellow employees or the public at large, or the specific task to which the apprentice is to be assigned is of a nature that training cannot be provided by a journeyman.

(l) If an exemption is granted pursuant to subdivision (k) to an organization that represents contractors in a specific trade from the 1-to-5 ratio on a local or statewide basis, the member contractors shall not be required to submit individual applications for approval to local joint apprenticeship committees, if they are already covered by the local apprenticeship standards.

(m) (1) A contractor to whom a contract is awarded, who, in performing any of the work under the contract, employs journeymen or apprentices in any apprenticeable craft or trade shall contribute to the California Apprenticeship Council the same amount that the director determines is the prevailing amount of apprenticeship training contributions in the area of the public works site. A contractor may take as a credit for payments to the council any amounts paid by the contractor to an approved apprenticeship program that can supply apprentices to the site of the public works project. The contractor may add the amount of the contributions in computing his or her bid for the contract.

(2) (A) At the conclusion of the 2002-03 fiscal year and each fiscal year thereafter, the California Apprenticeship Council shall distribute training contributions received by the council under this subdivision, less the expenses of the Department of Industrial Relations for administering this subdivision, by making grants to approved apprenticeship programs for the purpose of training apprentices. The grant funds shall be distributed as follows:

(i) If there is an approved multiemployer apprenticeship program serving the same craft or trade and geographic area for which the training contributions were made to the council, a grant to that program shall be made.

(ii) If there are two or more approved multiemployer apprenticeship programs serving the same craft or trade and county for which the training contributions were made to the council, the grant shall be divided among those programs based on the number of apprentices from that county registered in each program.

(iii) All training contributions not distributed under clauses (i) and (ii) shall be used to defray the future expenses of the Department of Industrial Relations for the administration and enforcement of apprenticeship and preapprenticeship standards and requirements under this code.

(B) An apprenticeship program shall only be eligible to receive grant funds pursuant to this subdivision if the apprenticeship program agrees, prior to the receipt of any grant funds, to keep adequate records that document the expenditure of grant funds and to make all records available to the Department of Industrial Relations so that the Department of Industrial Relations is able to verify that grant funds were used solely for

training apprentices. For purposes of this subparagraph, adequate records include, but are not limited to, invoices, receipts, and canceled checks that account for the expenditure of grant funds. This subparagraph shall not be deemed to require an apprenticeship program to provide the Department of Industrial Relations with more documentation than is necessary to verify the appropriate expenditure of grant funds made pursuant to this subdivision.

(C) The Department of Industrial Relations shall verify that grants made pursuant to this subdivision are used solely to fund training apprentices. If an apprenticeship program is unable to demonstrate how grant funds are expended or if an apprenticeship program is found to be using grant funds for purposes other than training apprentices, then the apprenticeship program shall not be eligible to receive any future grant pursuant to this subdivision and the Department of Industrial Relations may initiate the process to rescind the registration of the apprenticeship program.

(3) All training contributions received pursuant to this subdivision shall be deposited in the Apprenticeship Training Contribution Fund, which is hereby created in the State Treasury. Upon appropriation by the Legislature, all moneys in the Apprenticeship Training Contribution Fund shall be used for the purpose of carrying out this subdivision and to pay the expenses of the Department of Industrial Relations.

(n) The body awarding the contract shall cause to be inserted in the contract stipulations to effectuate this section. The stipulations shall fix the responsibility of compliance with this section for all apprenticeable occupations with the prime contractor.

(o) This section does not apply to contracts of general contractors or to contracts of specialty contractors not bidding for work through a general or prime contractor when the contracts of general contractors or those specialty contractors involve less than thirty thousand dollars (\$30,000).

(p) An awarding body that implements an approved labor compliance program in accordance with subdivision (b) of Section 1771.5 may, with the approval of the director, assist in the enforcement of this section under the terms and conditions prescribed by the director.

(Amended by Stats. 2018, Ch. 704, Sec. 17. (AB 235) Effective September 22, 2018.)

1777.6. An employer or a labor union shall not refuse to accept otherwise qualified employees as registered apprentices on any public works on any basis listed in subdivision (a) of Section 12940 of the Government Code, as those bases are defined in Sections 12926 and 12926.1 of the Government Code, except as provided in Section 3077 of this code and Section 12940 of the Government Code.

(Amended by Stats. 2004, Ch. 788, Sec. 15. Effective January 1, 2005.)

1777.7. (a) (1) If the Labor Commissioner or his or her designee determines after an investigation that a contractor or subcontractor knowingly violated Section 1777.5, the contractor and any subcontractor responsible for the violation shall forfeit, as a civil penalty to the state or political subdivision on whose behalf the contract is made or awarded, not more than one hundred dollars (\$100) for each full calendar day of noncompliance. The amount of this penalty may be reduced by the Labor Commissioner if the amount of the penalty would be disproportionate to the severity of the violation. A contractor or subcontractor that knowingly commits a second or subsequent violation within a three-year period, if the noncompliance results in apprenticeship training not being provided as required by this chapter, shall forfeit as a civil penalty the sum of not more than three hundred dollars (\$300) for each full calendar day of noncompliance.

(2) In lieu of the penalty provided for in this subdivision, the Labor Commissioner may, for a first-time violation and with the concurrence of an apprenticeship program described in subdivision (d) of Section 1777.5, order the contractor or subcontractor to provide apprentice employment equivalent to the work hours that would have been provided for apprentices during the period of noncompliance.

(b) The Labor Commissioner shall consider, in setting the amount of a monetary penalty, all of the following circumstances:

- (1) Whether the violation was intentional.
- (2) Whether the party has committed other violations of Section 1777.5.
- (3) Whether, upon notice of the violation, the party took steps to voluntarily remedy the violation.
- (4) Whether, and to what extent, the violation resulted in lost training opportunities for apprentices.
- (5) Whether, and to what extent, the violation otherwise harmed apprentices or apprenticeship programs.

(c) (1) The Labor Commissioner or his or her designee shall issue a civil wage and penalty assessment, in accordance with the provisions of Section 1741, upon determination of penalties assessed under subdivisions (a) and (b). Review of a civil wage and penalty assessment issued under this subdivision may be requested in accordance with the provisions of Section 1742. The regulations of the Director of Industrial Relations, which govern proceedings for review of civil wage and penalty assessments and the withholding of contract payments under Article 1 (commencing with Section 1720) and Article 2 (commencing with Section 1770), shall apply.

(2) For purposes of this section, a determination issued pursuant to subdivision (a) or (b) includes a determination that has been approved by the Labor Commissioner and issued by an awarding body that has been authorized to assist the director in the enforcement of Section 1777.5 pursuant to subdivision (p) of that section. The Labor Commissioner may intervene in any proceeding for review of a determination issued by an awarding body. If the involvement of the Labor Commissioner in a labor compliance program enforcement action is limited to a review of the determination and the matter is resolved without litigation by or against the Labor Commissioner or the department, the awarding body shall enforce any applicable penalties, as specified in this section, and shall deposit any penalties and forfeitures collected in the General Fund.

(d) The determination of the Labor Commissioner as to the amount of the penalty imposed under subdivisions (a) and (b) shall be reviewable only for an abuse of discretion.

(e) If a subcontractor is found to have violated Section 1777.5, the prime contractor of the project is not liable for any penalties under subdivision (a) unless the prime contractor had knowledge of the subcontractor's failure to comply with the provisions of Section 1777.5 or unless the prime contractor fails to comply with any of the following requirements:

(1) The contract executed between the contractor and the subcontractor for the performance of work on the public works project shall include a copy of the provisions of Sections 1771, 1775, 1776, 1777.5, 1813, and 1815.

(2) The contractor shall continually monitor a subcontractor's use of apprentices required to be employed on the public works project pursuant to subdivision (d) of Section 1777.5, including, but not limited to, periodic review of the certified payroll of the subcontractor.

(3) Upon becoming aware of a failure of the subcontractor to employ the required number of apprentices, the contractor shall take corrective action, including, but not limited to, retaining funds due to the subcontractor for work performed on the public works project until the failure is corrected.

(4) Prior to making the final payment to the subcontractor for work performed on the public works project, the contractor shall obtain a declaration signed under penalty of perjury from the subcontractor that the subcontractor has employed the required number of apprentices on the public works project.

(f) The Division of Labor Standards Enforcement shall notify the contractor on a public works project within 15 days of the receipt by the division of a complaint that a subcontractor on that public works project knowingly violated Section 1777.5.

(g) The interpretation of Section 1777.5 and the substantive requirements of this section applicable to contractors or subcontractors shall be in accordance with the regulations of the California Apprenticeship Council.

(h) The Director of Industrial Relations may adopt regulations to establish guidelines for the imposition of monetary penalties.

(Repealed and added by Stats. 2014, Ch. 297, Sec. 3. (AB 2744) Effective January 1, 2015.)

1778. Every person, who individually or as a representative of an awarding or public body or officer, or as a contractor or subcontractor doing public work, or agent or officer thereof, who takes, receives, or conspires with another to take or receive, for his or her own use or the use of any other person any portion of the wages of any worker or working subcontractor, in connection with services rendered upon any public work is guilty of a felony.

(Amended by Stats. 2017, Ch. 28, Sec. 23. (SB 96) Effective June 27, 2017.)

1779. Any person or agent or officer thereof who charges, collects, or attempts to charge or collect, directly or indirectly, a fee or valuable consideration for registering any person for public work, or for giving information as to where such employment may be procured, or for placing, assisting in placing, or attempting to place, any person in public work, whether the person is to work directly for the State, or any political subdivision or for a contractor or subcontractor doing public work is guilty of a misdemeanor.

(Enacted by Stats. 1937, Ch. 90.)

1780. Any person acting on behalf of the State or any political subdivision, or any contractor or subcontractor or agent or representative thereof, doing any public work who places any order for the employment of a worker on public work where the filling of the order for employment involves the charging of a fee, or the receiving of a valuable consideration from any applicant for employment is guilty of a misdemeanor.

(Amended by Stats. 2017, Ch. 28, Sec. 24. (SB 96) Effective June 27, 2017.)

1781. (a) (1) Notwithstanding any other provision of law, a contractor may, subject to paragraphs (2) and (3), bring an action in a court of competent jurisdiction to recover from the body awarding a contract for a public work or otherwise undertaking any public work any increased costs incurred by the contractor as a result of any decision by the body, the Department of Industrial Relations, or a court that classifies, after the time at which the body accepts the contractor's bid or awards the contractor a contract in circumstances where no bid is solicited, the work covered by the bid or contract as a "public work," as defined in this chapter, to which Section 1771 applies, if that body, before the bid opening or awarding of the contract, failed to identify as a "public work," as defined in this chapter, in the bid specification or in the contract documents that portion of the work that the decision classifies as a "public work."

(2) The body awarding a contract for a public work or otherwise undertaking any public work is not liable for increased costs in an action described in paragraph (1) if all of the following conditions are met:

(A) The contractor did not directly submit a bid to, or directly contract with, that body.

(B) The body stated in the contract, agreement, ordinance, or other written arrangement by which it undertook the public work that the work described in paragraph (1) was a "public work," as defined in this chapter, to which Section 1771 applies, and obligated the party with whom the body makes its written arrangement to cause the work described in paragraph (1) to be performed as a "public work."

(C) The body fulfilled all of its duties, if any, under the Civil Code or any other provision of law pertaining to the body providing and maintaining bonds to secure the payment of contractors, including the payment of wages to workers performing the work described in paragraph (1).

(3) If a contractor did not directly submit a bid to, or directly contract with a body awarding a contract for, or otherwise undertaking a public work, the liability of that body in an action commenced by the contractor under subdivision (a) is limited to that portion of a judgment, obtained by that contractor against the body that solicited the contractor's bid or awarded the contract to the contractor, that the contractor is unable to satisfy. For purposes of this paragraph, a contractor may not be deemed to be unable to satisfy any portion of a judgment unless, in addition to other collection measures, the contractor has made a good faith attempt to collect that portion of the judgment against a surety bond, guarantee, or some other form of assurance.

(b) When construction has not commenced at the time a final decision by the Department of Industrial Relations or a court classifies all or part of the work covered by the bid or contract as a "public work," as defined in this chapter, the body that solicited the bid or awarded the contract shall rebid the "public work" covered by the contract as a "public work," any bid that was submitted and any contract that was executed for this work are null and void, and the contractor may not be compensated for any nonconstruction work already performed unless the body soliciting the bid or awarding the contract has agreed to compensate the contractor for this work.

(c) For purposes of this section:

(1) "Awarding body" does not include the Department of General Services, the Department of Transportation, or the Department of Water Resources.

(2) "Increased costs" includes, but is not limited to:

(A) Labor cost increases required to be paid to workers who perform or performed work on the "public work" as a result of the events described in subdivision (a).

(B) Penalties for a violation of this article for which the contractor is liable, and which violation is the result of the events described in subdivision (a).

(Added by Stats. 2003, Ch. 804, Sec. 2. Effective January 1, 2004.)

1782. (a) A charter city shall not receive or use state funding or financial assistance for a construction project if the city has a charter provision or ordinance that authorizes a contractor to not comply with the provisions of this article on any public works contract.

(b) A charter city shall not receive or use state funding or financial assistance for a construction project if the city has awarded, within the prior two years, a public works contract without requiring the contractor to comply with all of the provisions of this article. This subdivision shall not apply if the charter city's failure to include the prevailing wage or apprenticeship requirement in a particular contract was inadvertent and contrary to a city charter provision or ordinance that otherwise requires compliance with this article.

(c) A charter city is not disqualified by subdivision (a) from receiving or using state funding or financial assistance for its construction projects if the charter city has a local prevailing wage ordinance for all its public works contracts that includes requirements that in all respects are equal to or greater than the requirements imposed by the provisions of this article and that do not authorize a contractor to not comply with this article.

(d) For purposes of this section, the following shall apply:

(1) A public works contract does not include contracts for projects of twenty-five thousand dollars (\$25,000) or less when the project is for construction work, or projects of fifteen thousand dollars (\$15,000) or less when the project is for alteration, demolition, repair, or maintenance work.

(2) A charter city includes any agency of a charter city and any entity controlled by a charter city whose contracts would be subject to this article.

(3) A "construction project" means a project that involves the award of a public works contract.

(4) State funding or financial assistance includes direct state funding, state loans and loan guarantees, state tax credits, and any other type of state financial support for a construction project. State funding or financial assistance does not include revenues that charter cities are entitled to receive without conditions under the California Constitution.

(e) The Director of Industrial Relations shall maintain a list of charter cities that may receive and use state funding or financial assistance for their construction projects.

(f) (1) This section does not restrict a charter city from receiving or using state funding or financial assistance that was awarded to the city prior to January 1, 2015, or from receiving or using state funding or financial assistance to complete a contract that was awarded prior to January 1, 2015.

(2) A charter city is not disqualified by subdivision (b) from receiving or using state funding or financial assistance for its construction projects based on the city's failure to require a contractor to comply with this article in performing a contract the city advertised for bid or awarded prior to January 1, 2015.

(Added by Stats. 2013, Ch. 794, Sec. 2. (SB 7) Effective January 1, 2014.)

1784. (a) Notwithstanding any other law, a contractor may bring an action in a court of competent jurisdiction to recover from the hiring party that the contractor directly contracts with, any increased costs attributable solely to the provisions of this chapter, including, but not limited to, the difference between the wages actually paid to an employee and the wages that were required to be paid to an employee under this chapter, any penalties or other sums required to be paid under this chapter, and costs and attorney's fees for the action incurred by the contractor as a result of any decision by the Department of Industrial Relations, the Labor and Workforce Development Agency, or a court that classifies, after the time at which the hiring party accepts the contractor's bid, awards the contractor a contract under circumstances when no bid is solicited, or otherwise allows construction by the contractor to proceed, the work covered by the project, or any portion thereof, as a "public work," as defined in this chapter, except to the extent that either of the following is true:

(1) The owner or developer or its agent expressly advised the contractor that the work to be covered by the contract would be a "public work," as defined in this chapter, or is otherwise subject to the payment of prevailing wages.

(2) The hiring party expressly advised the contractor that the work subject to the contract would be a "public work," as defined in this chapter, or is otherwise subject to the payment of prevailing wages.

(b) (1) To be entitled to the recovery of increased costs described in subdivision (a), the contractor shall notify the hiring party and the owner or developer within 30 days after receipt of the notice of a decision by the Department of Industrial Relations or the Labor and Workforce Development Agency, or the initiation of any action in a court alleging, that the work covered by the project, or any portion thereof, is a "public work," as defined in this chapter.

(2) The notice provided pursuant to this subdivision shall set forth the legal name, address, and telephone number of the contractor, and the name, address, and telephone number of the contractor's representative, if

any, and shall be given by registered or certified mail, express mail, or overnight delivery by an express service carrier.

(c) A contractor is not required to list any prevailing wages or apprenticeship standard violations on a prequalification questionnaire that are the direct result of the failure of the owner or developer or its agent, or a hiring party, to notify the contractor that the project, or any portion thereof, was a "public work," as defined in this chapter.

(d) This section does not apply to private residential projects built on private property unless the project is built pursuant to an agreement with a state agency, redevelopment agency, or local public housing authority.

(e) This section does not apply if the conduct of the contractor caused the project to be a "public work," as defined in this chapter, or if the contractor has actual knowledge that the work is a "public work," as defined in this chapter.

(f) A contractor may seek recovery pursuant to this section only from a hiring party with whom the contractor has a direct contract.

(g) For purposes of this section, "contractor" means a person or entity licensed by the Contractors' State Licensing Board that has a direct contract with the hiring party to provide services on private property or for the benefit of a private owner or developer.

(h) For purposes of this section, "hiring party" means the party that has a direct contract for services provided by the contractor who is seeking recovery pursuant to subdivision (a) on a private works project that was subsequently determined to be a public work by the Department of Industrial Relations or the Labor and Workforce Development Agency, or by the initiation of any action in a court alleging that the work covered by the project, or any portion thereof, was a public work.

(Added by Stats. 2014, Ch. 161, Sec. 1. (AB 1939) Effective January 1, 2015.)

1785. (a) The director shall establish and maintain a strategic enforcement unit focused on construction, alteration, and repair projects. The unit shall enhance the department's enforcement of this code in construction, alteration, and repair projects, including projects funded pursuant to Section 50675.1.3 of the Health and Safety Code and other publicly funded residential construction projects. The unit shall have primary responsibility for enforcement of this code in construction projects subject to Section 50675.1.3 of the Health and Safety Code. Any funds appropriated to the department for purposes of this section shall be administered and allocated by the director.

(b) The strategic enforcement unit described in subdivision (a) shall provide technical assistance to local public entities related to both of the following:

(1) Best practices for monitoring and enforcing requirements pertaining to construction, alteration, and repair projects paid for in whole or in part out of public funds, including, but not limited to, this chapter.

(2) Outreach and engagement with workers, employers, and state certified apprenticeship programs connected to construction, alteration, and repair projects.

(Added by Stats. 2021, Ch. 111, Sec. 26. (AB 140) Effective July 19, 2021.)

APPENDIX D

CONSTRUCTION PLAN

CITY OF MISSION VIEJO

CONSTRUCTION PLANS FOR:

CITY-WIDE INSTALLATION OF AUDIBLE PEDESTRIAN PUSH BUTTON SYSTEMS (PRIORITIZED LOCATIONS ONLY)

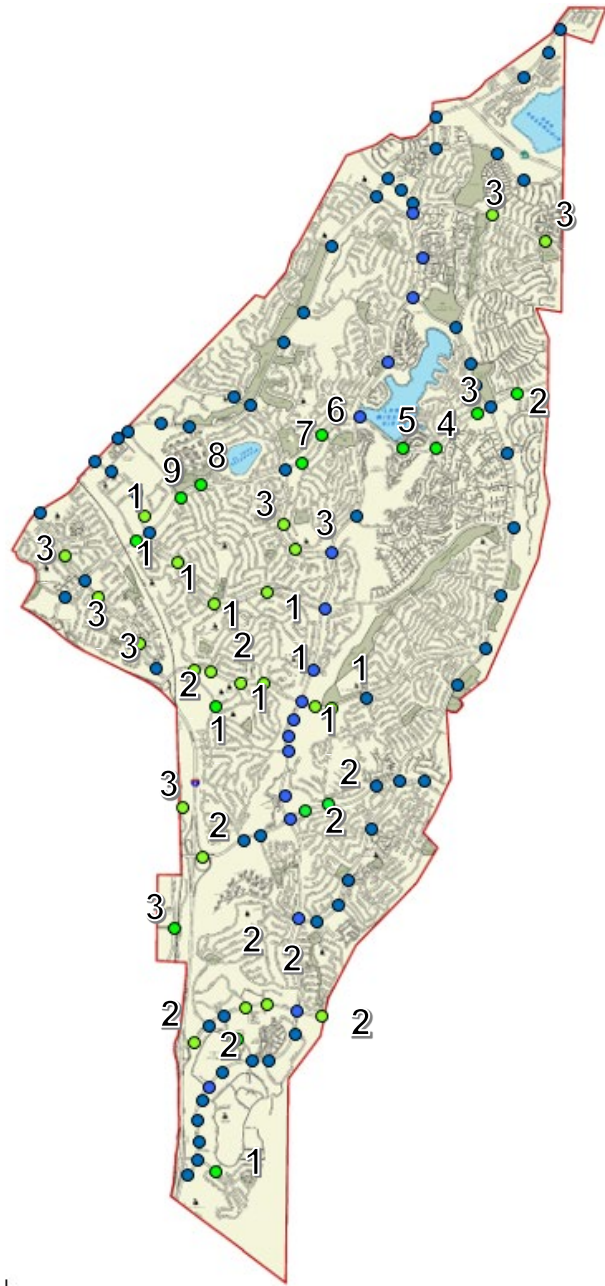

VICINITY MAP
NOT TO SCALE

- XX = LOCATION NUMBER
- = TRAFFIC SIGNALS **WITHOUT** AUDIBLE PED PUSH BUTTON SYSTEMS (38) **[PRIORITIZED (24)]**
 - = TRAFFIC SIGNALS WITH AUDIBLE PED PUSH BUTTON SYSTEMS (77)

CIP 23255



LOCATION INDEX

LOCATION NUMBER

- 1 AVERY PKWY AT PLATA PLACE (6)
- 2 ALICIA PKWY AT RUSTIC OAK (4)
- 3 **ALICIA PKWY AT OLYMPIAD PLAZA (4)**
- 4 **ALICIA PKWY AT CALLE AZORIN (8)**
- 5 **ALICIA PKWY @ CYPRESS (8)**
- 6 **ALICIA PKWY AT VIA AURORA (8)**
- 7 **ALICIA PKWY AT VIA BURGOS (4)**
- 8 **ALICIA PKWY AT CORONEL (8)**
- 9 **ALICIA PKWY AT VIA LINDA (4)**
- 10 **ALICIA PKWY AT VIA FABRICANTE (4)**
- 11 JERONIMO RD AT VALYERMO (4)
- 12 **JERONIMO RD AT MONTILLA (8)**
- 13 **JERONIMO RD AT CORDILLERA (8)**
- 14 **JERONIMO RD AT ACERO (6)**
- 15 **LA PAZ RD AT COMMERCE CENTER (8)**
- 16 **LA PAZ RD AT RALPHS DWY (8)**
- 17 **LA PAZ RD AT SPADRA (4)**
- 18 **LA PAZ RD AT PRADERA (4)**
- 19 **CHRISANTA DR AT PRADERA DR (8)**
- 20 **LA PAZ RD AT MOSQUERO (6)**
- 21 **LA PAZ RD AT CHRISANTA DR (8)**
- 22 OSO PKWY AT PACIFIC HILLS / ALPERA (8)
- 23 OSO PKWY AT MARKETPLACE (6)
- 24 OSO PKWY AT FAIRFIELD INN (2)
- 25 CROWN VALLEY AT JARDINES (8)
- 26 **CROWN VALLEY AT BELLOGENTE (8)**
- 27 CROWN VALLEY AT LOS ALTOS (6)
- 28 **CROWN VALLEY @ KALEIDOSCOPE (6)**
- 29 **MEDICAL CENTER @ HOSPITAL (6)**

LOCATION NUMBER

- 30 **MUIRLANDS @ MARATHON (4)**
- 31 MUIRLANDS @ SPARTAN (8)
- 32 MUIRLANDS @ ARES (8)
- 33 TRABUCO RD @ CARLOTA (4)
- 34 **TRABUCO @ PUERTA DE LUZ (8)**
- 35 **SANTA MARGARITA @ MONTRY(4)**
- 36 SANTA MARGARITA @ PROMEN (4)
- 37 CABOT @ VISTA VIEJO (4)
- 38 EL PASEO @ KRISPY KREME (2)

AUDIBLE PED PUSH BUTTONS (X)
TOTAL UNITS NEEDED= 226
TOTAL UNITS PRIORITIZED = 152
INTERSECTIONS PRIORITIZED = 24

RECOMMENDED FOR APPROVAL: M.G. 10/19/23

NO.	REVISIONS	RECMD'D	APPRV'D	DATE



CITY OF MISSION VIEJO
APPROVED BY:

10/19/2023
RICHARD SCHLESINGER, R.C.E. NO. 51160
CITY ENGINEER

TRAFFIC SIGNAL IMPROVEMENTS	CIP
TITLE SHEET	23255
	SHEET 1 OF 2

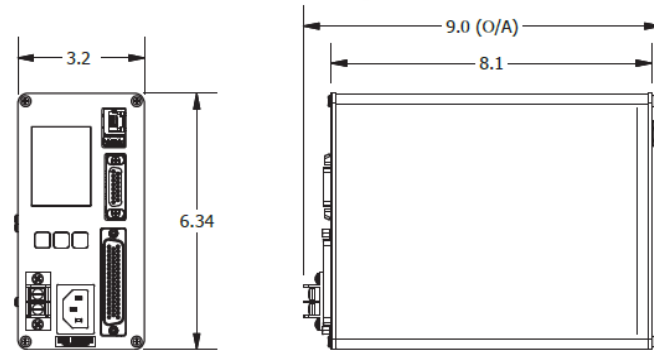

POLARA NAVIGATOR iN2 AUDIBLE PEDESTRIAN PUSH BUTTON STATION (2-WIRE iN2 5 B B 1) WITH (5" X 7") R10-3B BRAILLE SIGN DETAIL



Dimensions are in inches. All dimensions are reference only and subject to change without notice.

POLARA NAVIGATOR iN2 CENTRAL CONTROL UNIT ICCU-S DETAIL



50 Pin Cable Harness



iN2-SDLC-CABLE



iN2-SDLC-YCABLE (Splitter Cable)

GENERAL NOTES:

1. ALL MATERIAL AND WORK SHALL CONFORM TO THE LATEST EDITION OF CALTRANS STANDARD PLANS AND SPECIFICATIONS, AND CALIFORNIA MANUAL ON UNIFORM TRAFFIC CONTROL DEVICES.
2. THE CONTRACTOR SHALL VISIT THE JOB SITES PRIOR TO BIDDING.
3. PEDESTRIAN TRAFFIC MUST BE MAINTAINED AT ALL TIMES. PEDESTRIANS MAY BE RELOCATED ONTO PRIVATE PROPERTY WITH OWNERS PERMISSION ONLY. SIDEWALK MAY BE CLOSED WITH THE PERMISSION OF ENGINEER.
4. NO EQUIPMENT OR MATERIALS MAY BE STORED ON SIDEWALK AT ANY TIME.
5. THE CONTRACTOR SHALL NOTIFY THE CITY INSPECTORS 72 HOURS PRIOR TO CONSTRUCTION FOR SCHEDULING INSPECTIONS. CONTRACTOR TO CALL INSPECTION LINE AT (949) 470-3058.
6. THE CONTRACTOR SHALL BE RESPONSIBLE FOR ANY CLEAN UP ON CITY RIGHT-OF-WAY AFFECTED BY CONTRACTORS WORK. THE CONTRACTOR SHALL KEEP CITY RIGHT-OF-WAY CLEAN OF DEBRIS, WITH DUST AND OTHER NUISANCES BEING CONTROLLED AT ALL TIMES. METHOD OF STREET CLEANING SHALL BE DRY SWEEPING OF ALL PAVED AREAS.

CONSTRUCTION NOTES:

- 1 REMOVE EXISTING PEDESTRIAN PUSH BUTTON, FURNISH AND INSTALL NEW AUDIBLE PEDESTRIAN PUSH BUTTON PER SPECIFICATIONS. COMPLETE WIRING FOR INTENDED OPERATIONS.
- 2 FURNISH AND INSTALL NEW CENTRAL CONTROL UNIT (CCU) PER SPECIFICATIONS. COMPLETE WIRING FOR INTENDED OPERATIONS. CONSTRUCTOR TO VERIFY CUSTOM STREET NAME MESSAGES WITH CITY PRIOR TO ORDERING.

RECOMMENDED FOR APPROVAL: M.G. 10/19/23

NO.	REVISIONS	RECD'D	APPRV'D	DATE



CITY OF MISSION VIEJO
 APPROVED BY:

 10/19/2023
 RICHARD SCHLESINGER, R.C.E. NO. 51160
 CITY ENGINEER

TRAFFIC SIGNAL IMPROVEMENTS DETAIL SHEET	CIP 23255
	SHEET 2 OF 2

APPENDIX E

MISSION VIEJO ENCROACHMENT PERMIT

1. Location of Work: _____
2. Subject to the Encroachment Permit Special Provisions, the provisions of the Mission Viejo Municipal Code, and all the applicable ordinances, resolutions, and regulations of the City of Mission Viejo, a permit is hereby granted to:
Project Owner: _____
Street Address: _____
City: _____ State: _____ Zip: _____
3. Applicant's Name: _____
(MAY BE CONTRACTOR IF APPROPRIATE)
Address: _____
City: _____ State: _____ Zip: _____
Applicant's Phone No.: Day: _____ Emergency: _____
4. **DESCRIPTION OF WORK:** The City Engineer hereby authorizes the Permittee to do the work outlined below, including backfilling, compaction, and resurfacing:

5. Conditions on issuance of permit (MAY BE ATTACHED AS AN EXHIBIT): **SPECIAL PROVISIONS**

6. Est. Work Start Date _____ 7. Permit Expiration Date: _____

Signature of Applicant: _____ Date: _____

Name of Applicant (PLEASE PRINT): _____

INSPECTION FEE:	\$ _____	ISSUED BY:	_____
PENALTY FEE:	\$ _____	DATE:	_____
OTHER: _____	\$ _____		
BOND:	\$ _____	INSPECTOR:	_____ DATE: _____
TOTAL:	\$ _____	REMARKS:	_____
BOND TYPE/NO.:	_____	BOND RELEASED:	_____ DATE: _____

THIS PERMIT IS ISSUED SUBJECT TO THE FOLLOWING CONDITIONS:

Mission Viejo Municipal Code Sec. 14.03.150. - Conditions of permit.

The permit shall be subject to the following conditions, which shall be stated in the permit or incorporated by reference:

- (a) The City's encroachment permit special provisions shall be attached as conditions to the permit (unless otherwise determined by the director).
- (b) The permit must be kept at the site of the work and be shown, on demand, to any authorized representative of the City or any law enforcement officer.
- (c) The permit shall authorize work to be performed only within those rights-of-way over which the City has jurisdiction.
- (d) All work shall be performed in accordance with the provisions of the permit, and of all applicable laws, rules, and regulations of the City and any other public agency having jurisdiction and to the satisfaction of the city engineer.
- (e) The permit is nontransferable.
- (f) The city engineer may cancel the permit if the work authorized therein is not commenced within 120 days of the issuance of the permit and thereafter, in the reasonable opinion of the city engineer, is not diligently prosecuted to completion. Cancellation may be effected by written notice sent by regular mail to the permittee at the address shown on the application.
- (g) Not less than 24 hours before the commencement of any work authorized by the permit, the permittee shall apply to the city engineer for an inspection. In that application, the permittee shall specify the day and hour when, and the location at which, the work will be commenced. This requirement does not apply to emergency work on existing facilities within the public rights-of-way.
- (h) The permittee shall notify the city inspector when all work is completed.
- (i) The permittee shall provide proof of commercial general liability insurance in a form and an amount acceptable to Risk Management staff but not less than one million dollars per occurrence and two million dollars in the aggregate for bodily injury, personal injury, and property damage. The City, its officers, officials, employees, agents and volunteers shall be named as additional insureds on separate additional insured endorsement form(s) covering both ongoing and completed operations. Permittee shall also provide proof of automobile liability insurance in an amount not less than one million dollars per occurrence. Permittee shall provide City with proof of workers' compensation insurance per statutory limits and employer's liability insurance in an amount not less than one million dollars. The Risk Management Administrator may waive one or more of these requirements on a case-by-case basis if it is determined that the work to be performed creates minimal exposure of potential liability for the City.
- (j) In consideration for City issuance of the permit, permittee agrees to defend, indemnify, and hold harmless the City, and its officers, agents, and employees, against any and all penalties, liabilities, or loss resulting from any claim or court action arising out of any accident, loss, or damage to persons or property attributable to or occurring as a proximate result of any work undertaken by the permittee, its authorized agents, officers, representatives, or employees, under the permit. This indemnification will not apply to any claim or court action attributable to or arising out of the negligence or willful misconduct of the City, its officers, agents, or employees. City shall provide to permittee written notice of any claim or court action within ten days after the City learns of that claim or action. City shall assist in any defense that permittee must undertake in response to that claim or court action.
- (k) In the event of any controversy, claim, or dispute arising out of or relating to the permit, or the violation of any covenant contained therein, the prevailing party shall be entitled to receive from the losing party reasonable expenses, attorneys' fees, and costs.
- (l) The city engineer may, either at the time of issuance of the permit or at any time thereafter until completion of the work, prescribe reasonable time, place, and manner conditions as may be deemed necessary for the protection of the public right-of-way or public property, or for the prevention of undue interference with traffic, or to assure the safety of persons using the public rights-of-way.
- (m) All property owners and residents within 300 feet of the construction site who will be affected by the work (i.e., driveway closures, work on private property, sidewalk work in front of an adjoining property) shall be given written notice by the permittee a minimum of 48 hours prior to the start of work. This written notice shall be provided using door hangers, and the permittee shall print on the notice its contact telephone number. Any damage to private property shall be repaired by the permittee.
- (n) No excavations shall be made until after a permittee has called, at least 48 hours in advance, the Underground Service Alert (U.S.A.) of Southern California and has obtained a "digalert" identification number. No work shall be done under an encroachment permit until a Digalert identification number is obtained.
- (o) A permittee must comply with all regulations, including all stormwater best management practices, as specified in section 6.65.100 of the Municipal Code, and as required by the director.
- (p) All trenches and cuts that meet the criteria set forth in the City's encroachment permit special provisions and that are within two feet of gutter lip shall be cold planed to gutter lip.
- (q) Excavations and open cuts are prohibited within streets that have been reconstructed or overlaid with a new surface within the previous five years, or slurry sealed within the previous two years, except during emergencies as determined by the director in accordance with section 14.03.200 of the Municipal Code.
- (r) At the option of the city engineer, a permit for facilities that are actively under construction may be revoked at any time after the City provides permittee with reasonable advance notice of revocation stating a lawful cause for revocation and removal whenever:
 - (1) It appears to the city engineer that the continuance of the permitted work, whether because of changed conditions or otherwise, interferes with safe public use of the right-of-way involved; or
 - (2) The permittee fails to comply with or violates any City ordinance, safety regulations, or any material condition of the permit in a manner that precludes the safe use of the right-of-way by the public.

Upon revocation of the permit, permittee shall be responsible for the removal of the permitted improvement and restoration of the public right-of-way and public property to its pre-existing condition. If the permittee fails to remove the improvement and to restore the public right-of-way or public property within a reasonable period of time and as specified in the City's notice of revocation, the City shall be authorized to remove that improvement and to restore the public right-of-way or public property at the permittee's expense without any further notice to the permittee.

- (s) With regard to any permit application that is subject to the special provisions for large above-grade facilities set forth in section 14.03.220 of the Municipal Code, the requirements applicable to those large above-grade facilities proposed by a permit applicant shall be stated in the permit or incorporated by reference.

(Ord. No. 06-268, § 2, 5-19-08)

I have read the above Conditions of Approval: _____
(Applicant's Initials)

APPENDIX F

VENDOR APPLICATION FORM



City of Mission Viejo

200 Civic Center
Mission Viejo, CA 92691
Phone (949) 470-3059

purchasing@cityofmissionviejo.org

Vendor Approval Application

Please type or print in black ink. All vendor information must be complete and application must be signed. A signed Form W-9 must accompany this application.

Name of City Employee requesting this information: _____

Business Information:

*Company Name _____

*Address _____ *Suite _____

*City _____ *State _____ *Zip _____

*Contact Name/Title _____ Email _____

*Phone () _____ *Website _____

Accts Receivable Contact Name _____ E-Mail _____

*Remit Address _____ *State _____ *Zip _____

Accts Receivable Phone _____

Where is your DBA registered? _____

Year Established _____ Incorporated: Year _____ State _____

Product or Services provided _____

Standard Terms:

Net 30 2% 10 Net 30 Other _____

Current California License or Certifications(s) *(Examples: Contractor, Instructors, Health Dept, Architectural, Sports/Fitness, etc.):*

Type _____ Number _____

Type _____ Number _____

Type _____ Number _____

DIR Registration *(if applicable)* _____ Number _____

Company Ownership:

Sole Proprietorship Partnership Corporation Other *(please indicate)* _____

*Information is subject to disclosure under the Public Record Act

Principal Ownership or Corporate Officers:

Name _____ Title _____

Name _____ Title _____

Name _____ Title _____

References:

Please list three companies with whom you are currently doing business

Company Name _____ Phone (_____) _____

Address _____ Suite _____

City _____ State _____ Zip _____

Company Name _____ Phone (_____) _____

Address _____ Suite _____

City _____ State _____ Zip _____

Company Name _____ Phone (_____) _____

Address _____ Suite _____

City _____ State _____ Zip _____

Do you have a relationship with any existing City of Mission Viejo employee, Commissioner, Council member or Board member? YES NO If yes, please describe relationship below:

Certification:

Under penalty of perjury, I certify that all information provided on this application is true and correct.

Signature of Company Officer _____ Title _____

Please Print Name _____ Date _____

APPENDIX G

W9 REQUEST FOR TAXPAYER

By signing the filled-out form, you:

1. Certify that the TIN you are giving is correct (or you are waiting for a number to be issued),
2. Certify that you are not subject to backup withholding, or
3. Claim exemption from backup withholding if you are a U.S. exempt payee. If applicable, you are also certifying that as a U.S. person, your allocable share of any partnership income from a U.S. trade or business is not subject to the withholding tax on foreign partners' share of effectively connected income, and
4. Certify that FATCA code(s) entered on this form (if any) indicating that you are exempt from the FATCA reporting, is correct. See *What is FATCA reporting*, later, for further information.

Note: If you are a U.S. person and a requester gives you a form other than Form W-9 to request your TIN, you must use the requester's form if it is substantially similar to this Form W-9.

Definition of a U.S. person. For federal tax purposes, you are considered a U.S. person if you are:

- An individual who is a U.S. citizen or U.S. resident alien;
- A partnership, corporation, company, or association created or organized in the United States or under the laws of the United States;
- An estate (other than a foreign estate); or
- A domestic trust (as defined in Regulations section 301.7701-7).

Special rules for partnerships. Partnerships that conduct a trade or business in the United States are generally required to pay a withholding tax under section 1446 on any foreign partners' share of effectively connected taxable income from such business. Further, in certain cases where a Form W-9 has not been received, the rules under section 1446 require a partnership to presume that a partner is a foreign person, and pay the section 1446 withholding tax. Therefore, if you are a U.S. person that is a partner in a partnership conducting a trade or business in the United States, provide Form W-9 to the partnership to establish your U.S. status and avoid section 1446 withholding on your share of partnership income.

In the cases below, the following person must give Form W-9 to the partnership for purposes of establishing its U.S. status and avoiding withholding on its allocable share of net income from the partnership conducting a trade or business in the United States.

- In the case of a disregarded entity with a U.S. owner, the U.S. owner of the disregarded entity and not the entity;
- In the case of a grantor trust with a U.S. grantor or other U.S. owner, generally, the U.S. grantor or other U.S. owner of the grantor trust and not the trust; and
- In the case of a U.S. trust (other than a grantor trust), the U.S. trust (other than a grantor trust) and not the beneficiaries of the trust.

Foreign person. If you are a foreign person or the U.S. branch of a foreign bank that has elected to be treated as a U.S. person, do not use Form W-9. Instead, use the appropriate Form W-8 or Form 8233 (see Pub. 515, *Withholding of Tax on Nonresident Aliens and Foreign Entities*).

Nonresident alien who becomes a resident alien. Generally, only a nonresident alien individual may use the terms of a tax treaty to reduce or eliminate U.S. tax on certain types of income. However, most tax treaties contain a provision known as a "saving clause." Exceptions specified in the saving clause may permit an exemption from tax to continue for certain types of income even after the payee has otherwise become a U.S. resident alien for tax purposes.

If you are a U.S. resident alien who is relying on an exception contained in the saving clause of a tax treaty to claim an exemption from U.S. tax on certain types of income, you must attach a statement to Form W-9 that specifies the following five items.

1. The treaty country. Generally, this must be the same treaty under which you claimed exemption from tax as a nonresident alien.
2. The treaty article addressing the income.
3. The article number (or location) in the tax treaty that contains the saving clause and its exceptions.
4. The type and amount of income that qualifies for the exemption from tax.
5. Sufficient facts to justify the exemption from tax under the terms of the treaty article.

Example. Article 20 of the U.S.-China income tax treaty allows an exemption from tax for scholarship income received by a Chinese student temporarily present in the United States. Under U.S. law, this student will become a resident alien for tax purposes if his or her stay in the United States exceeds 5 calendar years. However, paragraph 2 of the first Protocol to the U.S.-China treaty (dated April 30, 1984) allows the provisions of Article 20 to continue to apply even after the Chinese student becomes a resident alien of the United States. A Chinese student who qualifies for this exception (under paragraph 2 of the first protocol) and is relying on this exception to claim an exemption from tax on his or her scholarship or fellowship income would attach to Form W-9 a statement that includes the information described above to support that exemption.

If you are a nonresident alien or a foreign entity, give the requester the appropriate completed Form W-8 or Form 8233.

Backup Withholding

What is backup withholding? Persons making certain payments to you must under certain conditions withhold and pay to the IRS 24% of such payments. This is called "backup withholding." Payments that may be subject to backup withholding include interest, tax-exempt interest, dividends, broker and barter exchange transactions, rents, royalties, nonemployee pay, payments made in settlement of payment card and third party network transactions, and certain payments from fishing boat operators. Real estate transactions are not subject to backup withholding.

You will not be subject to backup withholding on payments you receive if you give the requester your correct TIN, make the proper certifications, and report all your taxable interest and dividends on your tax return.

Payments you receive will be subject to backup withholding if:

1. You do not furnish your TIN to the requester,
2. You do not certify your TIN when required (see the instructions for Part II for details),
3. The IRS tells the requester that you furnished an incorrect TIN,
4. The IRS tells you that you are subject to backup withholding because you did not report all your interest and dividends on your tax return (for reportable interest and dividends only), or
5. You do not certify to the requester that you are not subject to backup withholding under 4 above (for reportable interest and dividend accounts opened after 1983 only).

Certain payees and payments are exempt from backup withholding. See *Exempt payee code*, later, and the separate Instructions for the Requester of Form W-9 for more information.

Also see *Special rules for partnerships*, earlier.

What is FATCA Reporting?

The Foreign Account Tax Compliance Act (FATCA) requires a participating foreign financial institution to report all United States account holders that are specified United States persons. Certain payees are exempt from FATCA reporting. See *Exemption from FATCA reporting code*, later, and the Instructions for the Requester of Form W-9 for more information.

Updating Your Information

You must provide updated information to any person to whom you claimed to be an exempt payee if you are no longer an exempt payee and anticipate receiving reportable payments in the future from this person. For example, you may need to provide updated information if you are a C corporation that elects to be an S corporation, or if you no longer are tax exempt. In addition, you must furnish a new Form W-9 if the name or TIN changes for the account; for example, if the grantor of a grantor trust dies.

Penalties

Failure to furnish TIN. If you fail to furnish your correct TIN to a requester, you are subject to a penalty of \$50 for each such failure unless your failure is due to reasonable cause and not to willful neglect.

Civil penalty for false information with respect to withholding. If you make a false statement with no reasonable basis that results in no backup withholding, you are subject to a \$500 penalty.

Criminal penalty for falsifying information. Willfully falsifying certifications or affirmations may subject you to criminal penalties including fines and/or imprisonment.

Misuse of TINs. If the requester discloses or uses TINs in violation of federal law, the requester may be subject to civil and criminal penalties.

Specific Instructions

Line 1

You must enter one of the following on this line; **do not** leave this line blank. The name should match the name on your tax return.

If this Form W-9 is for a joint account (other than an account maintained by a foreign financial institution (FFI)), list first, and then circle, the name of the person or entity whose number you entered in Part I of Form W-9. If you are providing Form W-9 to an FFI to document a joint account, each holder of the account that is a U.S. person must provide a Form W-9.

a. **Individual.** Generally, enter the name shown on your tax return. If you have changed your last name without informing the Social Security Administration (SSA) of the name change, enter your first name, the last name as shown on your social security card, and your new last name.

Note: ITIN applicant: Enter your individual name as it was entered on your Form W-7 application, line 1a. This should also be the same as the name you entered on the Form 1040/1040A/1040EZ you filed with your application.

b. **Sole proprietor or single-member LLC.** Enter your individual name as shown on your 1040/1040A/1040EZ on line 1. You may enter your business, trade, or “doing business as” (DBA) name on line 2.

c. **Partnership, LLC that is not a single-member LLC, C corporation, or S corporation.** Enter the entity’s name as shown on the entity’s tax return on line 1 and any business, trade, or DBA name on line 2.

d. **Other entities.** Enter your name as shown on required U.S. federal tax documents on line 1. This name should match the name shown on the charter or other legal document creating the entity. You may enter any business, trade, or DBA name on line 2.

e. **Disregarded entity.** For U.S. federal tax purposes, an entity that is disregarded as an entity separate from its owner is treated as a “disregarded entity.” See Regulations section 301.7701-2(c)(2)(iii). Enter the owner’s name on line 1. The name of the entity entered on line 1 should never be a disregarded entity. The name on line 1 should be the name shown on the income tax return on which the income should be reported. For example, if a foreign LLC that is treated as a disregarded entity for U.S. federal tax purposes has a single owner that is a U.S. person, the U.S. owner’s name is required to be provided on line 1. If the direct owner of the entity is also a disregarded entity, enter the first owner that is not disregarded for federal tax purposes. Enter the disregarded entity’s name on line 2, “Business name/disregarded entity name.” If the owner of the disregarded entity is a foreign person, the owner must complete an appropriate Form W-8 instead of a Form W-9. This is the case even if the foreign person has a U.S. TIN.

Line 2

If you have a business name, trade name, DBA name, or disregarded entity name, you may enter it on line 2.

Line 3

Check the appropriate box on line 3 for the U.S. federal tax classification of the person whose name is entered on line 1. Check only one box on line 3.

IF the entity/person on line 1 is a(n) . . .	THEN check the box for . . .
• Corporation	Corporation
• Individual • Sole proprietorship, or • Single-member limited liability company (LLC) owned by an individual and disregarded for U.S. federal tax purposes.	Individual/sole proprietor or single-member LLC
• LLC treated as a partnership for U.S. federal tax purposes, • LLC that has filed Form 8832 or 2553 to be taxed as a corporation, or • LLC that is disregarded as an entity separate from its owner but the owner is another LLC that is not disregarded for U.S. federal tax purposes.	Limited liability company and enter the appropriate tax classification. (P= Partnership; C= C corporation; or S= S corporation)
• Partnership	Partnership
• Trust/estate	Trust/estate

Line 4, Exemptions

If you are exempt from backup withholding and/or FATCA reporting, enter in the appropriate space on line 4 any code(s) that may apply to you.

Exempt payee code.

- Generally, individuals (including sole proprietors) are not exempt from backup withholding.
- Except as provided below, corporations are exempt from backup withholding for certain payments, including interest and dividends.
- Corporations are not exempt from backup withholding for payments made in settlement of payment card or third party network transactions.
- Corporations are not exempt from backup withholding with respect to attorneys’ fees or gross proceeds paid to attorneys, and corporations that provide medical or health care services are not exempt with respect to payments reportable on Form 1099-MISC.

The following codes identify payees that are exempt from backup withholding. Enter the appropriate code in the space in line 4.

- 1—An organization exempt from tax under section 501(a), any IRA, or a custodial account under section 403(b)(7) if the account satisfies the requirements of section 401(f)(2)
- 2—The United States or any of its agencies or instrumentalities
- 3—A state, the District of Columbia, a U.S. commonwealth or possession, or any of their political subdivisions or instrumentalities
- 4—A foreign government or any of its political subdivisions, agencies, or instrumentalities
- 5—A corporation
- 6—A dealer in securities or commodities required to register in the United States, the District of Columbia, or a U.S. commonwealth or possession
- 7—A futures commission merchant registered with the Commodity Futures Trading Commission
- 8—A real estate investment trust
- 9—An entity registered at all times during the tax year under the Investment Company Act of 1940
- 10—A common trust fund operated by a bank under section 584(a)
- 11—A financial institution
- 12—A middleman known in the investment community as a nominee or custodian
- 13—A trust exempt from tax under section 664 or described in section 4947

The following chart shows types of payments that may be exempt from backup withholding. The chart applies to the exempt payees listed above, 1 through 13.

IF the payment is for . . .	THEN the payment is exempt for . . .
Interest and dividend payments	All exempt payees except for 7
Broker transactions	Exempt payees 1 through 4 and 6 through 11 and all C corporations. S corporations must not enter an exempt payee code because they are exempt only for sales of noncovered securities acquired prior to 2012.
Barter exchange transactions and patronage dividends	Exempt payees 1 through 4
Payments over \$600 required to be reported and direct sales over \$5,000 ¹	Generally, exempt payees 1 through 5 ²
Payments made in settlement of payment card or third party network transactions	Exempt payees 1 through 4

¹ See Form 1099-MISC, Miscellaneous Income, and its instructions.

² However, the following payments made to a corporation and reportable on Form 1099-MISC are not exempt from backup withholding: medical and health care payments, attorneys' fees, gross proceeds paid to an attorney reportable under section 6045(f), and payments for services paid by a federal executive agency.

Exemption from FATCA reporting code. The following codes identify payees that are exempt from reporting under FATCA. These codes apply to persons submitting this form for accounts maintained outside of the United States by certain foreign financial institutions. Therefore, if you are only submitting this form for an account you hold in the United States, you may leave this field blank. Consult with the person requesting this form if you are uncertain if the financial institution is subject to these requirements. A requester may indicate that a code is not required by providing you with a Form W-9 with "Not Applicable" (or any similar indication) written or printed on the line for a FATCA exemption code.

A—An organization exempt from tax under section 501(a) or any individual retirement plan as defined in section 7701(a)(37)

B—The United States or any of its agencies or instrumentalities

C—A state, the District of Columbia, a U.S. commonwealth or possession, or any of their political subdivisions or instrumentalities

D—A corporation the stock of which is regularly traded on one or more established securities markets, as described in Regulations section 1.1472-1(c)(1)(i)

E—A corporation that is a member of the same expanded affiliated group as a corporation described in Regulations section 1.1472-1(c)(1)(i)

F—A dealer in securities, commodities, or derivative financial instruments (including notional principal contracts, futures, forwards, and options) that is registered as such under the laws of the United States or any state

G—A real estate investment trust

H—A regulated investment company as defined in section 851 or an entity registered at all times during the tax year under the Investment Company Act of 1940

I—A common trust fund as defined in section 584(a)

J—A bank as defined in section 581

K—A broker

L—A trust exempt from tax under section 664 or described in section 4947(a)(1)

M—A tax exempt trust under a section 403(b) plan or section 457(g) plan

Note: You may wish to consult with the financial institution requesting this form to determine whether the FATCA code and/or exempt payee code should be completed.

Line 5

Enter your address (number, street, and apartment or suite number). This is where the requester of this Form W-9 will mail your information returns. If this address differs from the one the requester already has on file, write NEW at the top. If a new address is provided, there is still a chance the old address will be used until the payor changes your address in their records.

Line 6

Enter your city, state, and ZIP code.

Part I. Taxpayer Identification Number (TIN)

Enter your TIN in the appropriate box. If you are a resident alien and you do not have and are not eligible to get an SSN, your TIN is your IRS individual taxpayer identification number (ITIN). Enter it in the social security number box. If you do not have an ITIN, see *How to get a TIN* below.

If you are a sole proprietor and you have an EIN, you may enter either your SSN or EIN.

If you are a single-member LLC that is disregarded as an entity separate from its owner, enter the owner's SSN (or EIN, if the owner has one). Do not enter the disregarded entity's EIN. If the LLC is classified as a corporation or partnership, enter the entity's EIN.

Note: See *What Name and Number To Give the Requester*, later, for further clarification of name and TIN combinations.

How to get a TIN. If you do not have a TIN, apply for one immediately. To apply for an SSN, get Form SS-5, Application for a Social Security Card, from your local SSA office or get this form online at www.SSA.gov. You may also get this form by calling 1-800-772-1213. Use Form W-7, Application for IRS Individual Taxpayer Identification Number, to apply for an ITIN, or Form SS-4, Application for Employer Identification Number, to apply for an EIN. You can apply for an EIN online by accessing the IRS website at www.irs.gov/Businesses and clicking on Employer Identification Number (EIN) under Starting a Business. Go to www.irs.gov/Forms to view, download, or print Form W-7 and/or Form SS-4. Or, you can go to www.irs.gov/OrderForms to place an order and have Form W-7 and/or SS-4 mailed to you within 10 business days.

If you are asked to complete Form W-9 but do not have a TIN, apply for a TIN and write "Applied For" in the space for the TIN, sign and date the form, and give it to the requester. For interest and dividend payments, and certain payments made with respect to readily tradable instruments, generally you will have 60 days to get a TIN and give it to the requester before you are subject to backup withholding on payments. The 60-day rule does not apply to other types of payments. You will be subject to backup withholding on all such payments until you provide your TIN to the requester.

Note: Entering "Applied For" means that you have already applied for a TIN or that you intend to apply for one soon.

Caution: A disregarded U.S. entity that has a foreign owner must use the appropriate Form W-8.

Part II. Certification

To establish to the withholding agent that you are a U.S. person, or resident alien, sign Form W-9. You may be requested to sign by the withholding agent even if item 1, 4, or 5 below indicates otherwise.

For a joint account, only the person whose TIN is shown in Part I should sign (when required). In the case of a disregarded entity, the person identified on line 1 must sign. Exempt payees, see *Exempt payee code*, earlier.

Signature requirements. Complete the certification as indicated in items 1 through 5 below.

1. Interest, dividend, and barter exchange accounts opened before 1984 and broker accounts considered active during 1983.

You must give your correct TIN, but you do not have to sign the certification.

2. Interest, dividend, broker, and barter exchange accounts opened after 1983 and broker accounts considered inactive during 1983.

You must sign the certification or backup withholding will apply. If you are subject to backup withholding and you are merely providing your correct TIN to the requester, you must cross out item 2 in the certification before signing the form.

3. Real estate transactions.

You must sign the certification. You may cross out item 2 of the certification.

4. Other payments.

You must give your correct TIN, but you do not have to sign the certification unless you have been notified that you have previously given an incorrect TIN. "Other payments" include payments made in the course of the requester's trade or business for rents, royalties, goods (other than bills for merchandise), medical and health care services (including payments to corporations), payments to a nonemployee for services, payments made in settlement of payment card and third party network transactions, payments to certain fishing boat crew members and fishermen, and gross proceeds paid to attorneys (including payments to corporations).

5. Mortgage interest paid by you, acquisition or abandonment of secured property, cancellation of debt, qualified tuition program payments (under section 529), ABLE accounts (under section 529A), IRA, Coverdell ESA, Archer MSA or HSA contributions or distributions, and pension distributions.

You must give your correct TIN, but you do not have to sign the certification.

What Name and Number To Give the Requester

For this type of account:	Give name and SSN of:
1. Individual	The individual
2. Two or more individuals (joint account) other than an account maintained by an FFI	The actual owner of the account or, if combined funds, the first individual on the account ¹
3. Two or more U.S. persons (joint account maintained by an FFI)	Each holder of the account
4. Custodial account of a minor (Uniform Gift to Minors Act)	The minor ²
5. a. The usual revocable savings trust (grantor is also trustee)	The grantor-trustee ¹
b. So-called trust account that is not a legal or valid trust under state law	The actual owner ¹
6. Sole proprietorship or disregarded entity owned by an individual	The owner ³
7. Grantor trust filing under Optional Form 1099 Filing Method 1 (see Regulations section 1.671-4(b)(2)(i)(A))	The grantor*
For this type of account:	Give name and EIN of:
8. Disregarded entity not owned by an individual	The owner
9. A valid trust, estate, or pension trust	Legal entity ⁴
10. Corporation or LLC electing corporate status on Form 8832 or Form 2553	The corporation
11. Association, club, religious, charitable, educational, or other tax-exempt organization	The organization
12. Partnership or multi-member LLC	The partnership
13. A broker or registered nominee	The broker or nominee

For this type of account:	Give name and EIN of:
14. Account with the Department of Agriculture in the name of a public entity (such as a state or local government, school district, or prison) that receives agricultural program payments	The public entity
15. Grantor trust filing under the Form 1041 Filing Method or the Optional Form 1099 Filing Method 2 (see Regulations section 1.671-4(b)(2)(i)(B))	The trust

¹ List first and circle the name of the person whose number you furnish. If only one person on a joint account has an SSN, that person's number must be furnished.

² Circle the minor's name and furnish the minor's SSN.

³ You must show your individual name and you may also enter your business or DBA name on the "Business name/disregarded entity" name line. You may use either your SSN or EIN (if you have one), but the IRS encourages you to use your SSN.

⁴ List first and circle the name of the trust, estate, or pension trust. (Do not furnish the TIN of the personal representative or trustee unless the legal entity itself is not designated in the account title.) Also see *Special rules for partnerships*, earlier.

*Note: The grantor also must provide a Form W-9 to trustee of trust.

Note: If no name is circled when more than one name is listed, the number will be considered to be that of the first name listed.

Secure Your Tax Records From Identity Theft

Identity theft occurs when someone uses your personal information such as your name, SSN, or other identifying information, without your permission, to commit fraud or other crimes. An identity thief may use your SSN to get a job or may file a tax return using your SSN to receive a refund.

To reduce your risk:

- Protect your SSN,
- Ensure your employer is protecting your SSN, and
- Be careful when choosing a tax preparer.

If your tax records are affected by identity theft and you receive a notice from the IRS, respond right away to the name and phone number printed on the IRS notice or letter.

If your tax records are not currently affected by identity theft but you think you are at risk due to a lost or stolen purse or wallet, questionable credit card activity or credit report, contact the IRS Identity Theft Hotline at 1-800-908-4490 or submit Form 14039.

For more information, see Pub. 5027, Identity Theft Information for Taxpayers.

Victims of identity theft who are experiencing economic harm or a systemic problem, or are seeking help in resolving tax problems that have not been resolved through normal channels, may be eligible for Taxpayer Advocate Service (TAS) assistance. You can reach TAS by calling the TAS toll-free case intake line at 1-877-777-4778 or TTY/TDD 1-800-829-4059.

Protect yourself from suspicious emails or phishing schemes.

Phishing is the creation and use of email and websites designed to mimic legitimate business emails and websites. The most common act is sending an email to a user falsely claiming to be an established legitimate enterprise in an attempt to scam the user into surrendering private information that will be used for identity theft.

The IRS does not initiate contacts with taxpayers via emails. Also, the IRS does not request personal detailed information through email or ask taxpayers for the PIN numbers, passwords, or similar secret access information for their credit card, bank, or other financial accounts.

If you receive an unsolicited email claiming to be from the IRS, forward this message to phishing@irs.gov. You may also report misuse of the IRS name, logo, or other IRS property to the Treasury Inspector General for Tax Administration (TIGTA) at 1-800-366-4484. You can forward suspicious emails to the Federal Trade Commission at spam@uce.gov or report them at www.ftc.gov/complaint. You can contact the FTC at www.ftc.gov/idtheft or 877-IDTHEFT (877-438-4338). If you have been the victim of identity theft, see www.IdentityTheft.gov and Pub. 5027.

Visit www.irs.gov/IdentityTheft to learn more about identity theft and how to reduce your risk.

Privacy Act Notice

Section 6109 of the Internal Revenue Code requires you to provide your correct TIN to persons (including federal agencies) who are required to file information returns with the IRS to report interest, dividends, or certain other income paid to you; mortgage interest you paid; the acquisition or abandonment of secured property; the cancellation of debt; or contributions you made to an IRA, Archer MSA, or HSA. The person collecting this form uses the information on the form to file information returns with the IRS, reporting the above information. Routine uses of this information include giving it to the Department of Justice for civil and criminal litigation and to cities, states, the District of Columbia, and U.S. commonwealths and possessions for use in administering their laws. The information also may be disclosed to other countries under a treaty, to federal and state agencies to enforce civil and criminal laws, or to federal law enforcement and intelligence agencies to combat terrorism. You must provide your TIN whether or not you are required to file a tax return. Under section 3406, payers must generally withhold a percentage of taxable interest, dividend, and certain other payments to a payee who does not give a TIN to the payer. Certain penalties may also apply for providing false or fraudulent information.