

PLAN

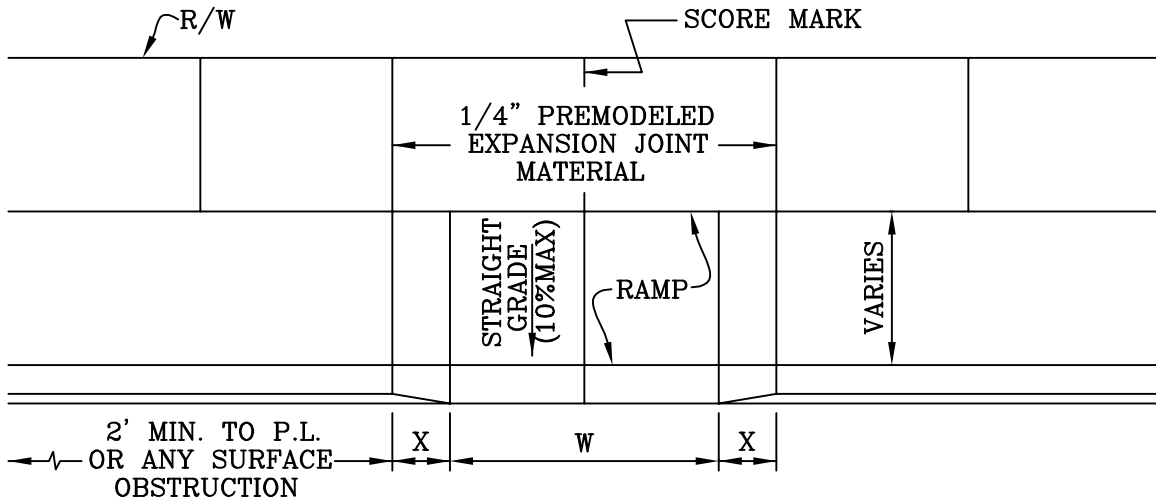

ELEVATION

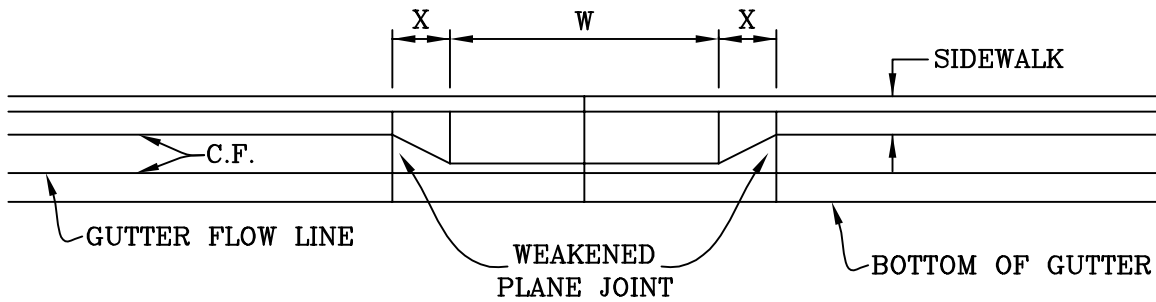

VALUES OF "W"	MIN.
RESIDENTIAL	12'
* COMM. & IND. ONE-WAY	14'
TWO-WAY	28'

* USE OF STANDARD PLAN 306 IN COMMERCIAL AND INDUSTRIAL AREAS REQUIRES APPROVAL OF THE CITY ENGINEER.

CITY OF MISSION VIEJO



DRIVEWAY APPROACH

306

Rich Schloinger

08/01/05

APPROVED BY: CITY ENGINEER RCE 51160

DATE

SHT 1 OF 2

CROSS SECTION

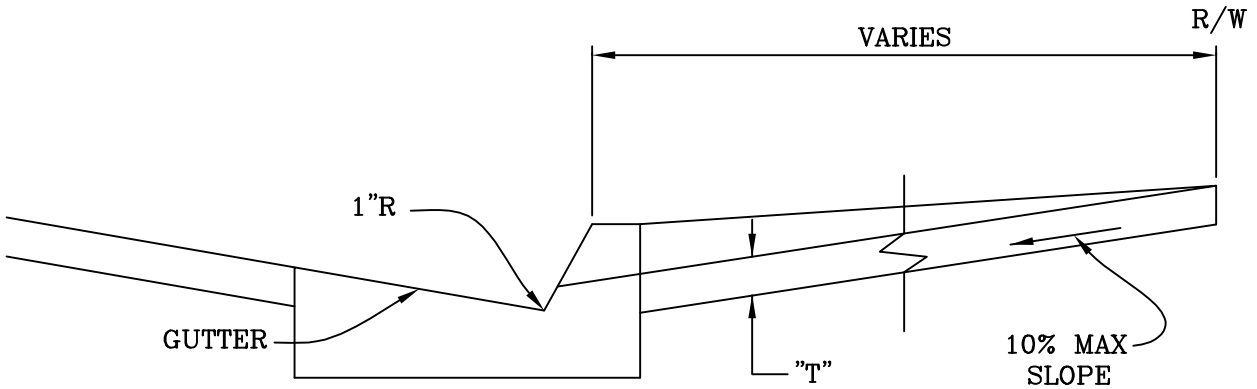

NOTES:

1. UNDER NO CIRCUMSTANCES WILL SAW CUTTING IN THE GUTTER FLOW LINE BE ALLOWED TO REMOVE CURB.
2. COMMERCIAL, INDUSTRIAL, AND RESIDENTIAL DRIVEWAYS SERVING 5 OR MORE DWELLING UNITS SHALL HAVE 6" OF BASE MATERIAL UNDER GUTTER, CURB RAMP AND SIDEWALK FROM TOP OF "X" TO TOP OF "X".
3. GUTTER, RAMP, AND SIDEWALK THICKNESS "T" SHALL BE 6" (RESIDENTIAL) OR 8" (COMMERCIAL / INDUSTRIAL) FROM TOP OF "X" TO TOP OF "X".
4. WEAKENED PLANE JOINTS SHALL BE 1 1/2" DEEP WITH 1/8" RADIUS EDGES.
5. COMMERCIAL AND INDUSTRIAL DRIVEWAY APPROACHES SHALL USE STANDARD No. 307 UNLESS THE CITY ENGINEER APPROVES THE USE OF STANDARD PLAN 306.
6. DRIVEWAY APRON SHALL BE PORTLAND CEMENT CONCRETE.
7. "X" SHALL BE 3' FOR 6" CURB, 4' FOR 8" CURB.
8. DRIVEWAYS WITH "W" LESS THAN 20' SHALL HAVE ONE (1) SCORE MARK AT 1/2 "W". DRIVEWAYS WITH "W" OVER 20' SHALL HAVE SCORE MARKS NOT TO EXCEED 10' ON CENTER.
9. FOR NEW DRIVEWAY CONSTRUCTION ON EXISTING STREETS, 12" OF ASPHALT FROM THE EDGE OF THE GUTTER SHALL BE SAWCUT AND REMOVED.

CITY OF MISSION VIEJO



DRIVEWAY APPROACH

306

Rich Schloinger

08/01/05

APPROVED BY: CITY ENGINEER RCE 51160

DATE

SHT 2 OF 2