

MOUNTING DETAIL

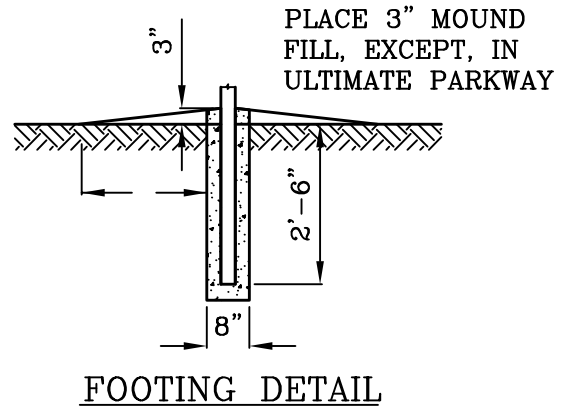

SEE SHT. 2 AND 3 FOR NOTES

CITY OF MISSION VIEJO

STREET NAME SIGNS

STANDARD
PLAN NO.

327



APPROVED

RCE 30190

DATE

SHT 1 OF 4

Robert Anderson

9-23-03

NOTES:

1. EXACT LOCATIONS OF STREET NAME SIGNS ARE TO BE SHOWN ON STREET IMPROVEMENT PLANS. SEE SHEET 3 FOR PLACEMENT CRITERIA. SEE SHEET 3 FOR STREET NAME SIGN NOTES.
2. ALUMINUM ALLOY FOR ALL COMPONENTS SHALL CONFORM TO SPECIFICATIONS PUBLISHED BY THE ALUMINUM ASSOCIATION.
3. THE 9" SIGN SHALL FACE ARTERIAL TRAFFIC; THE 6" SIGN SHALL FACE LOCAL STREET TRAFFIC.
 - A. USE A 5/8" x 18" CARRIAGE BOLT FOR 6" AND 9" SIGN COMBINATION. USE A 5/8" x 21" CARRIAGE BOLT FOR 9" AND 9" SIGN COMBINATION. CARRIAGE BOLT SHALL BE GALVANIZED MILD STEEL.
 - B. ORNAMENTAL TOP AND CENTER ACROSS SADDLE SHALL BE ANODIZED AND CAST FORM ALUMINUM CASTING ALLOY 319.
 - C. ANODIZED 2 1/2" POST CAP, CAST FROM ALUMINUM CASTING ALLOY 391, WITH THREE 3/8" STAINLESS STEEL SET SCREWS AND ONE 1/4" x 3/4" STEEL ROLL PIN.

SIZE:

THE SIGNS SHALL BE IN TWO SIZES:

1. FOR TRAFFIC ON LOCAL STREETS, THE LENGTH OF THE SIGN FACE SHALL BE IN SIX-INCH MULTIPLES FROM 24 TO 36 INCHES.
2. FOR TRAFFIC ON ARTERIAL STREETS, THE LENGTH OF THE SIGN FACE SHALL BE IN SIX-INCH MULTIPLES FROM 24 TO 42 INCHES. THE SIGN SHALL HAVE REINFORCING RIBS OR CROSS MEMBERS TO RETAIN THE RIGIDITY OF THE PIECES.

FINISH:

SIGN FACE SHALL BE OF WIDE ANGLE, SMOOTH SURFACE REFLECTIVE SHEETING, CONFORMING TO FEDERAL SPECIFICATION L-S-300A CLASSIFICATION 1.2 TYPE I (CLASS 1 OR 2) TABLE II REFLECTIVITY 1. LEGEND SHALL BE SILVER WITH REVERSE SCREEN GREEN BACKGROUND. SHEETING SHALL BE BOUNDED TO REFLECTIVE ALUMINUM ALLOY SIGN BLANKS AND BE OF THE SAME SHAPE AND SIZE.

CITY OF MISSION VIEJO



SPECIAL PROVISIONS
STREET NAME SIGNS

STANDARD
PLAN NO.

Robert Anderson

9-23-03

327

APPROVED

RCE 30190

DATE

SHT 2 OF 4

LETTERING:

1. THE 6-INCH WIDTH SIGN SHALL HAVE 4-INCH CAPITAL LETTERS.
2. THE 9-INCH WIDTH SIGN SHALL HAVE 5-INCH CAPITAL LETTERS AND 3 3/4 INCH LOWER CASE LETTERS.
3. THE STREET NAME SHALL BE CENTERED ON THE SIGN FACE.
4. STREET NAME PREFIXES (SUCH AS CALLE, CAMINO) SHALL BE SHOWN IN 2-INCH CAPITAL LETTERS; STREET NAME SUFFIXES (SUCH AS DRIVE, STREET, ROAD), AND BLOCK NUMBERS SHALL NOT BE SHOWN.
5. SPACING OF THE LETTERS TO BE AS FOLLOWS:
 - a. THE END SPACE SHALL NOT BE LESS THAN 1/3 THE HEIGHT OF THE UPPER CASE LETTER BEING USED.
 - b. THE SPACING BETWEEN WORDS ON NAMES WITH TWO OR MORE WORDS SHALL NOT BE LESS THAN 2/3 THE HEIGHT OF THE UPPER CASE LETTER BEING USED.
 - c. THE SPACING BETWEEN LETTERS SHALL BE 1 TO 1.5 TIMES THE STROKE WIDTH (WIDTH OF LETTERING MATERIAL), DEPENDENT UPON COMBINATION OF LETTERS.

CITY OF MISSION VIEJO



SPECIAL PROVISIONS
STREET NAME SIGNS

STANDARD
PLAN NO.

327

Robert Anderson *9-23-03*

APPROVED RCE 30190 DATE

SHT 3 OF 4

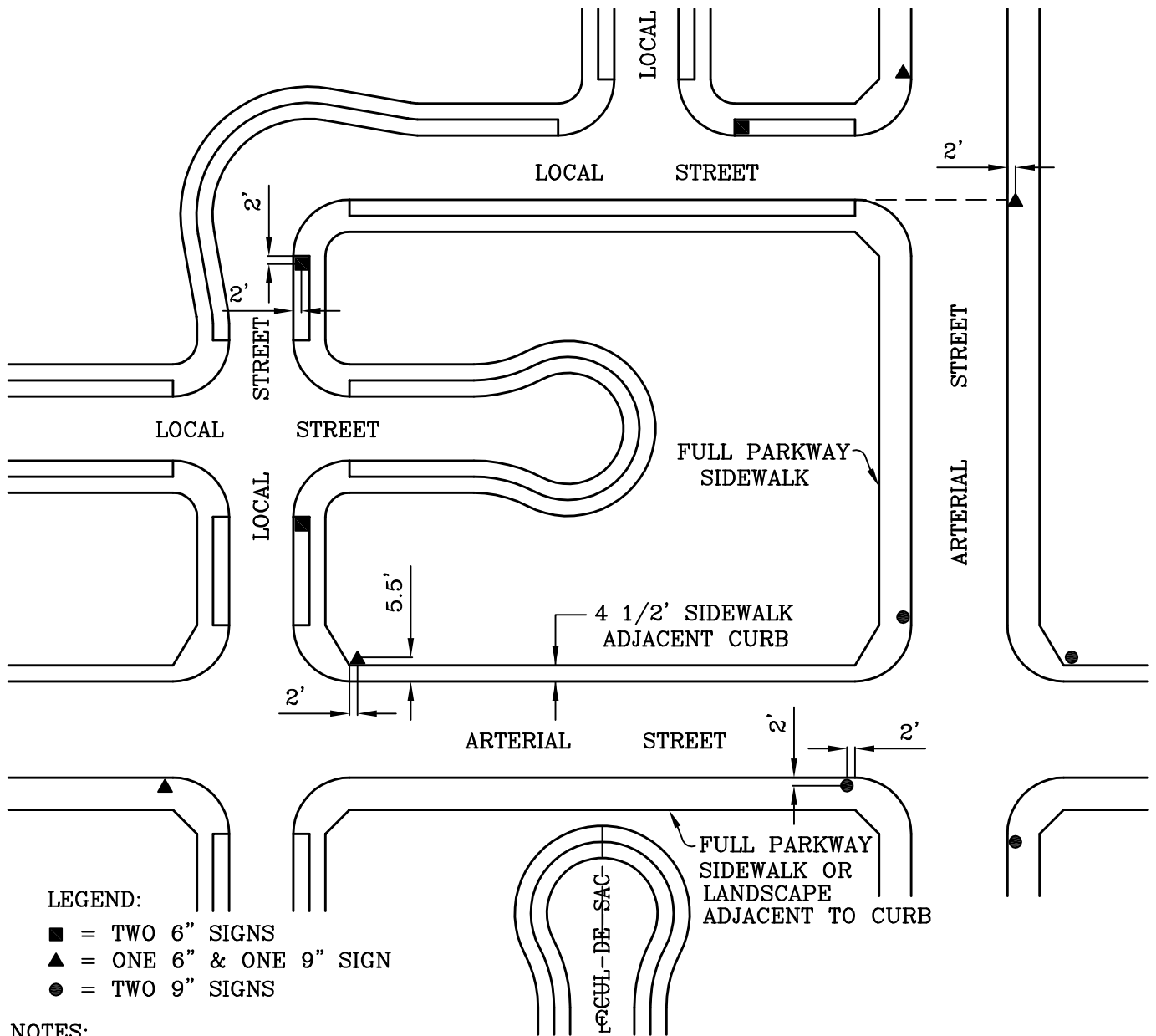

NOTES:

1. SEE SHTS. 1 & 2 FOR STREET NAME SIGN DETAILS AND NOTES.
2. THE 9" SIGN SHALL FACE ARTERIAL TRAFFIC; THE 6" SHALL FACE LOCAL STREET TRAFFIC.
3. STREET NAME SIGNS SHALL BE PLACED AT THE NEAR RIGHT APPROACH OF MAJOR TRAFFIC FLOW.
4. ONE SIGN SHALL BE PLACED AT THE INTERSECTION OF TWO LOCAL STREETS.
5. TWO SIGNS SHALL BE PLACED AT THE INTERSECTION OF AN ARTERIAL STREET WITH A LOCAL STREET.
6. FOUR SIGNS SHALL BE PLACED AT THE INTERSECTION OF TWO ARTERIAL STREETS.
7. STREET NAME SIGNS SHALL BE OMITTED AT SIGNALIZED INTERSECTIONS.

CITY OF MISSION VIEJO



STREET NAME SIGN LOCATION

STANDARD
PLAN NO.

327

Robert Anderson 9-23-03

APPROVED RCE 30190 DATE

SHT 4 OF 4