

| POINT | 6" TO 10" CF TRANS. DISTANCE BELOW T.C. | 8" TO 12" CF TRANS. DISTANCE BELOW T.C. |
|-------|---|---|
| a | .38' | .50' |
| b | .34' | .47' |

BASED ON 1.7% STREET CROSSFALL.

NOTES:

1. LOCAL DEPRESSION SHALL NOT BE CONSTRUCTED UNTIL CONNECTING CURB AND GUTTER HAS BEEN COMPLETED OR SHALL BE CONSTRUCTED MONOLITHICALLY WITH CONNECTING CURB AND GUTTER, UNLESS OTHERWISE APPROVED BY CITY ENGINEER.
2. LENGTH OF OPENING "L" SHALL BE SPECIFIED ON PLANS.
3. BOTH ENDS OF DEPRESSION SHALL BE SYMMETRICAL ABOUT CL OF OPENING IN SUMP CONDITION.
4. SEE STD. PLAN 404 FOR CURB OPENING DETAIL.
5. SEE STD. PLAN 321 FOR JOINT DETAILS.

CITY OF MISSION VIEJO



LOCAL DEPRESSION

STANDARD PLAN NO.

406

Robert Anderson 9-23-03

APPROVED

RCE 30190

DATE

SHT 1 OF 2

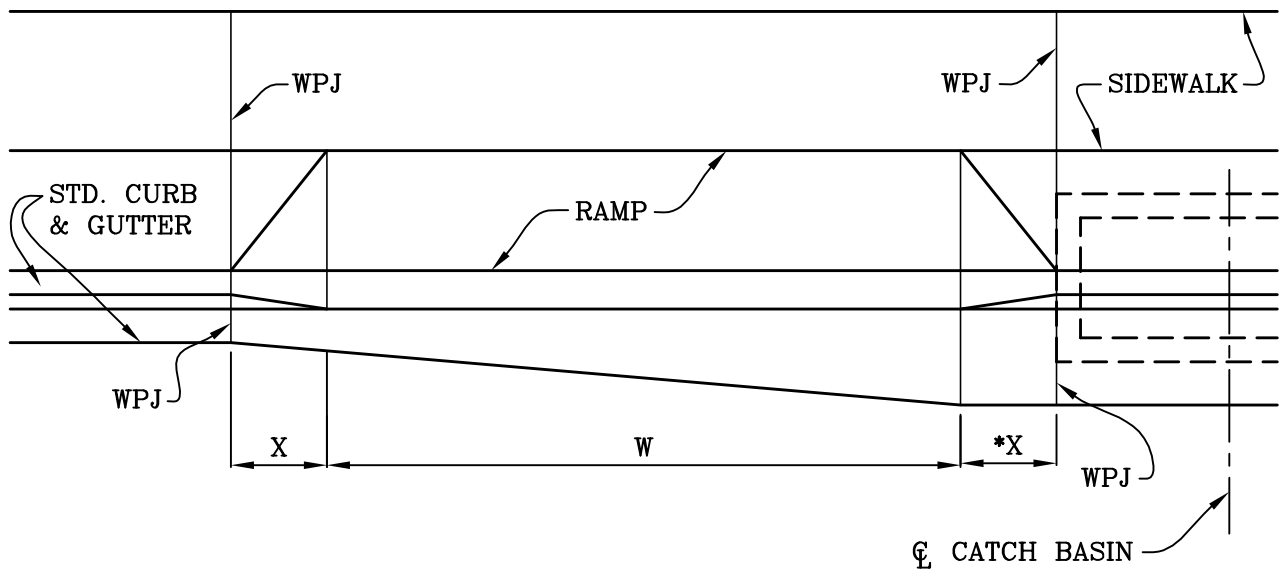
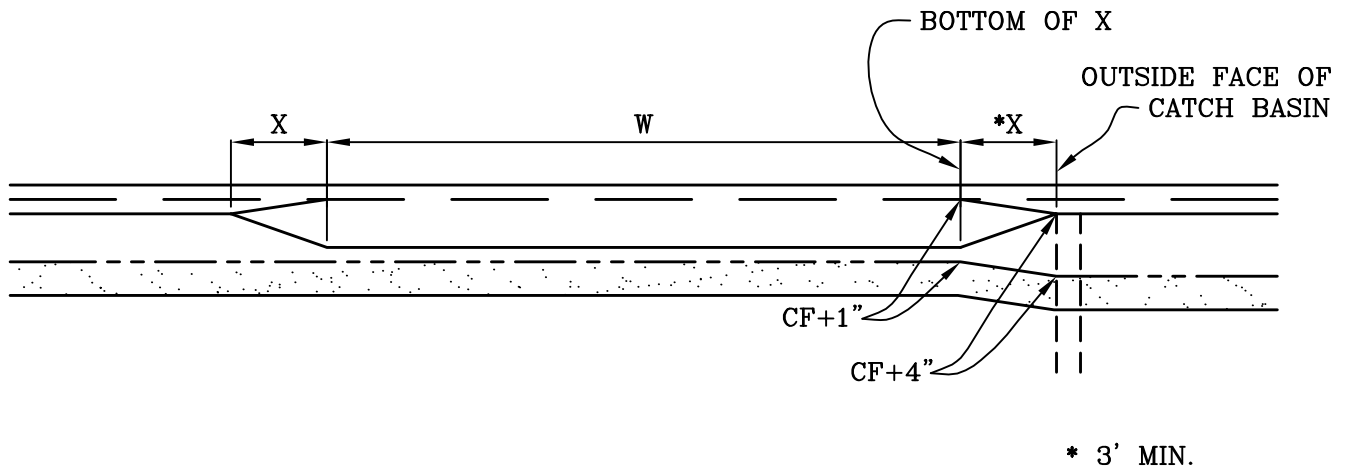

NOTES:

1. TYPE A LOCAL DEPRESSION SHALL BE USED ADJACENT TO DRIVEWAY DEPRESSIONS ONLY.
2. USE OF TYPE A LOCAL DEPRESSION MAY REQUIRE LENGTHENING OF INLET TO PROVIDE ADEQUATE HYDRAULIC CAPACITY.

CITY OF MISSION VIEJO

LOCAL DEPRESSION (TYPE A)

STANDARD
PLAN NO.

406



Robert Anderson

9-23-03

APPROVED

RCE 30190

DATE

SHT 2 OF 2